

# Length, Perimeter and Area



Name \_\_\_\_\_

# Series G – Length, Perimeter and Area

## Contents

### Topic 1 – Units of length (pp. 1–8)

Date completed

- choose units of measurement \_\_\_\_\_
- convert measurements \_\_\_\_\_
- estimate and measure \_\_\_\_\_
- size me up! – *investigate* \_\_\_\_\_
- how long? – *apply* \_\_\_\_\_

### Topic 2 – Perimeter (pp. 9–16)

- measure perimeters \_\_\_\_\_
- perimeters of composite shapes \_\_\_\_\_
- circumference \_\_\_\_\_
- circle work – *investigate* \_\_\_\_\_
- perimeter puzzles – *solve* \_\_\_\_\_

### Topic 3 – Area (pp. 17–26)

- square units \_\_\_\_\_
- find area using formulae \_\_\_\_\_
- find area of irregular and composite shapes \_\_\_\_\_
- area and perimeter \_\_\_\_\_
- area and perimeter puzzles – *solve* \_\_\_\_\_
- animal rescue – *investigate* \_\_\_\_\_

### Topic 4 – Scale and distance (pp. 27–34)

- scale drawings \_\_\_\_\_
- maps \_\_\_\_\_
- speed, time and distance \_\_\_\_\_
- all roads lead to Rome – *apply* \_\_\_\_\_
- where will it take you? – *investigate* \_\_\_\_\_

Series Authors:

Rachel Flenley

Nicola Herring

**Please note:**

These pages have been designed to print to 'shrink to printable area' as this is a common default setting on many computers. There may be minor discrepancies with measurements as individual printers and photocopiers print to slightly different proportions.

# Units of length – choose units of measurement

1 Brainstorm all the units you know for measuring length. Can you show how they are connected?

metre  $\xrightarrow{1\ 000\ m = 1\ km}$  kilometre

When measuring length, it is important to choose a suitable unit of measurement. Using millimetres as the unit to measure the distance between London and Moscow is not the most efficient choice. Think of all those zeros.

2 Choose the conventional unit of length (cm, m, km, mm) to measure the following:

a The length of your nose

b The distance between Australia and Italy

c The length of an Olympic swimming pool

d The length of a ladybird

e The height of a basketballer

f The width of a watermelon seed

g The length of the Trans-Siberian Railway

h The height of a Year 6 student

3 Would more than one choice of unit be appropriate for any of the items above? Which ones and which unit would you use?

---

4 Name 3 things you would measure in mm, cm, km:

mm

cm

km

## Units of length – choose units of measurement

- 5 Choose a distance in the school such as the length of your classroom, corridor or oval. Measure it in m, mm and cm. Record your measurements below. Which was easiest to use? Which would you recommend that someone else use if they were to do the same thing?

mm
cm
m

- 6 Play Unit Bingo with some friends. You'll each need a copy of the grid below. One of you will be the caller and the others will play. The players will need 16 counters each.

- 1 Fill in the rest of your bingo card with a mixture of items where length can be measured in different measurements. You'll want a mixture of cm, mm, m and km options.
- 2 The caller nominates a measurement – km, m, cm or mm. If you think you have an item that would most commonly be measured in that unit, call it out.
- 3 The group can discuss your choice and if they disagree, the caller makes the final decision as to whether you can cover the item with a counter. Obviously there may be more than 1 choice for an object. For example, you may accept both cm and mm as an answer for the french fry.
- 4 The first person to cover all their squares calls "Bingo" and wins.

<i>hand span</i>			
		<i>a french fry</i>	
<i>London to Paris</i>			
		<i>your tongue length</i>	

# Units of length – convert measurements

Measurements can be expressed using different units.

When we convert from a larger unit to a smaller unit, we multiply:

$$\text{cm} \rightarrow \text{mm} \quad 34 \text{ cm} = (34 \times 10) \text{ mm} = 340 \text{ mm}$$

When we convert from a smaller unit to a larger unit, we divide:

$$\text{cm} \rightarrow \text{m} \quad 34 \text{ cm} = (34 \div 100) \text{ m} = 0.34 \text{ m}$$

1 Express the lengths shown on the ruler in 2 ways:

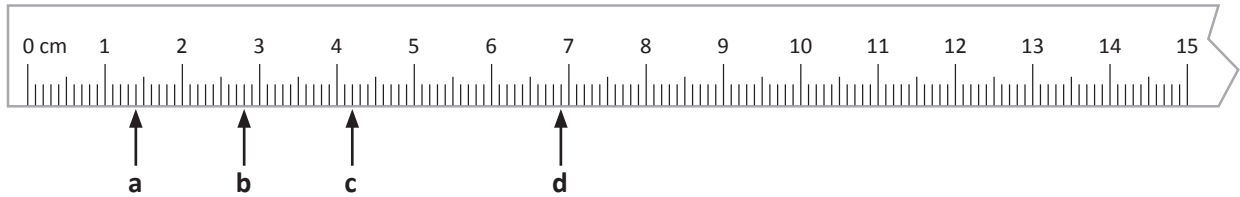

a  mm     cm

b  mm     cm

c  mm     cm

d  mm     cm

2 Convert these lengths to centimetres:

a 200 mm =  cm

b 405 mm =  cm

c 8 238 mm =  cm

d 2 m =  cm

e 19 m =  cm

f 450 m =  cm

3 Convert these lengths to metres:

a 400 cm =  m

b 28 cm =  m

c 3 250 mm =  m

d 482 cm =  m

e 123 cm =  m

f 7 777 mm =  m

g 4 341 mm =  m

h 187 cm =  m

i 198 mm =  m

Remember these key facts!  
 10 mm = 1 cm  
 100 cm = 1 m  
 1 000 m = 1 km



**REMEMBER**

## Units of length – convert measurements

When we order lengths it's easiest to convert them into the same unit first. Here, we are converting to cm:

14 cm 128 mm 1.1 m **convert** → 14 cm 12.8 cm 110 cm

Now we can clearly see the order of these lengths.

4 Put these measurements in order from shortest to longest:

a	13 cm	120 mm	3 m	
b	5 700 mm	5 m	540 cm	
c	3.25 m	300 cm	325 mm	

5 Use these *Guinness World Record* facts to fill in the missing values.

Source: *Guinness World Book Records 2008*

	metres	centimetres	millimetres
Longest tongue	0.095 m	cm	95 mm
Tallest living person	2.57 m	257 cm	mm
Longest hair	m	5 267 cm	mm
Longest fingernails	7.513 m	cm	7 513 mm
Smallest tooth	m	cm	3 mm
Longest leg hair	0.127 m	cm	mm

6 Choose one of the above measurements and work out the length of your equivalent body part. Express your measurement in three different units.

7 Without revealing your findings for question 6, ask your friend to measure you. Is their answer the same as yours? If not, why do you think the answers are different?

# Units of length – estimate and measure

In real life, we often estimate measurements. Can you think of a time you would estimate instead of measuring exactly? Or a time you would estimate first, then measure more precisely?

- 1 When we compare, we often use fractional language to help us. For example, “He was twice her size!” or “My bedroom is  $\frac{2}{3}$  the size of this.” Look at the top bar and then the bars below. What fraction of the top bar do you estimate that the lower bars represent?

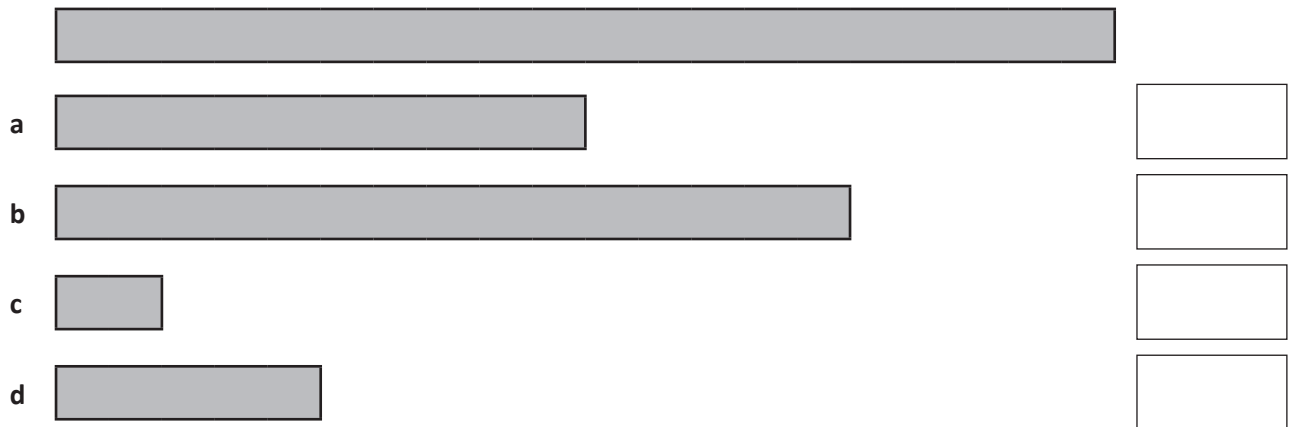

- 2 Draw each of these lines in mm:

- a 64 cm
- b 37 cm
- c 27 cm
- d 82 cm

- 3 Make a choice from the box (on the right) to fill the gaps in these statements:

- a A desk is about \_\_\_\_\_ metre high.
- b A basketballer is about \_\_\_\_\_ metres high.
- c A dinner fork is about 19 \_\_\_\_\_ long.
- d A soccer pitch is between 100 and 110 \_\_\_\_\_ long.
- e A crayon could be about \_\_\_\_\_ cm long.

centimetres

metres

1

8.6

2

# Units of length – estimate and measure

Comparing lengths or heights with a known measurement is a useful strategy. The known measurement is called a benchmark.

- 4 The average height of an adult woman is around 1.6 m and a man is around 1.8 m. Use these benchmarks to estimate the height of the objects below:

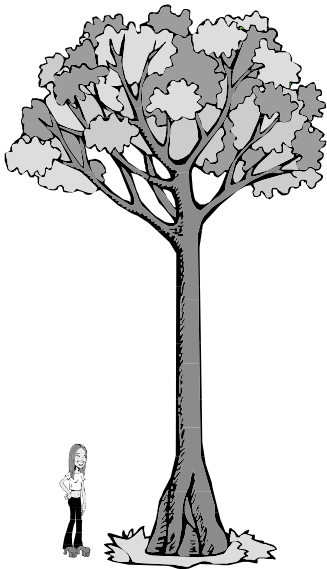

a

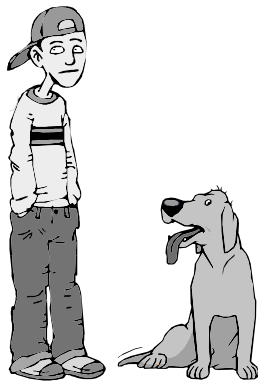

b

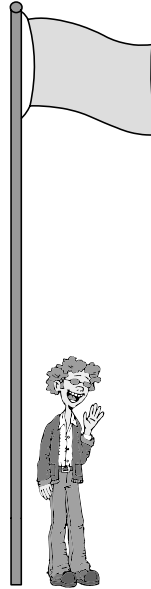

c



d

- 5 Measure yourself. Using that measurement as a benchmark, estimate the height of 5 objects around the school. Now measure them. How close were your estimations?

My height:

	Object	Estimation	Actual measurement
1			
2			
3			
4			
5			





Getting ready

The human body is a fascinating thing. In this activity you will work with a partner to compare the length of different parts of your body to find some common relationships between the measurements. You will record your measurements and findings.

You'll need a tape measure or strips of paper or lengths of string. A ruler may also help.

You'll need a pen and paper for recording your data.



What to do

Look at your foot. Consider the length, not how beautiful it is. Can you think of a part of your body that might be the same length? Make your prediction.

It is said that your foot is the same length as your forearm, from your wrist to your elbow. Do you think this is true for you? Test it out.

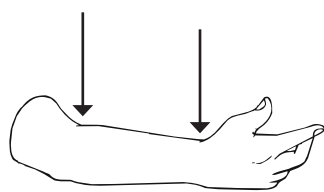

It is also said that the circumference (or length) of your neck is equal to twice the circumference of your wrist. Test that one out.

Now it's your turn to find some more. With a partner, measure at least 10 different body lengths and see if you can find connections between them.

You could measure the length of: your shin bone, your thigh bone, your navel to the floor, the top of your head to your navel, around your waist, around your head, the length of your head, or the distance between your eyes. The list goes on!

Can you find some measurements that are the same length?

Can you find some that are roughly double or half the size of each other?

What about some that are about one and a half times the length of each other?

Is measuring an exact science? What issues do you face?



What to do next

If this activity has interested you, you are in for a treat. Use the internet to research the terms 'divine proportions' or 'golden ratio'. What do you find?



Getting ready

In this activity work in groups of 4 to practise and improve on estimating lengths. Note the team average of 6 attempts and see how close your team average estimate can get to the actual measurement. This is about working together, not just about individual estimates.

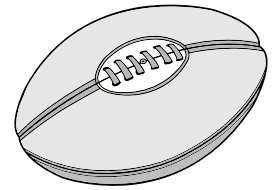

You'll need paper and a calculator.



What to do

- 1 Choose one action where length can be measured easily. You are going to measure the same action 6 times. Examples include the length of a jump, the distance of a ball throw or how far you can hop on one foot without faltering.
- 2 One person in the group performs the action. All group members make an estimation of its length. Record the estimations. Work out the average of the estimations. This is an important step – don't just rush to measure the length!
- 3 Now you can measure the length. As a whole group, how far out was your estimate? Record this on a table such as the one below:

Remember we work out averages by adding up all the estimates and dividing by the number of estimates.

$$\begin{array}{r}
 \text{A} \quad 35 \text{ cm} \\
 \text{B} \quad 40 \text{ cm} \\
 \text{C} \quad + 38 \text{ cm} \\
 \hline
 \quad 113 \text{ cm} \\
 \hline
 113 \div 3 = 37.66 \text{ cm}
 \end{array}$$

Measurement	Group average	Difference
1.25 m	1.13 m	0.12 m

- 4 Try the action again and go through the same steps. Was your estimate closer?
- 5 Repeat the activity until you have done it 6 times.



**REMEMBER**



What to do next

Share your process and results with the class.

Which groups improved with more practice? Did groups use strategies to assist them to get closer? If no improvement was shown, why do you think this was?

# Perimeter – measure perimeters

Perimeter is the length around a shape. The word originates from Greek and literally means 'around measure'.

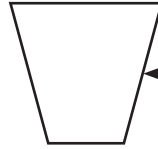

The boundary of this shape is the perimeter.

- 1 Choose 5 classroom objects. Using a piece of string or strips of paper, find their perimeters. Record your measurements in the table.

	Item	Perimeter
1		
2		
3		
4		
5		

- 2 Look carefully at the dimensions on each shape and find the perimeter. Express your answers in cm:

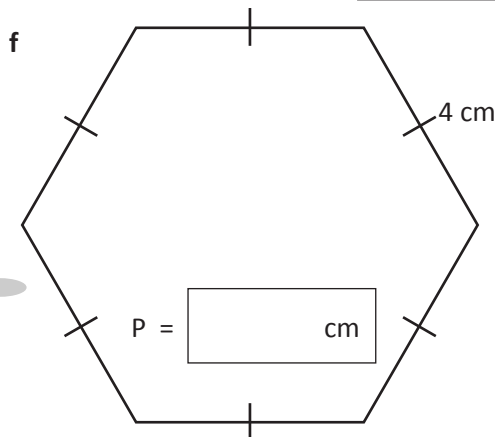
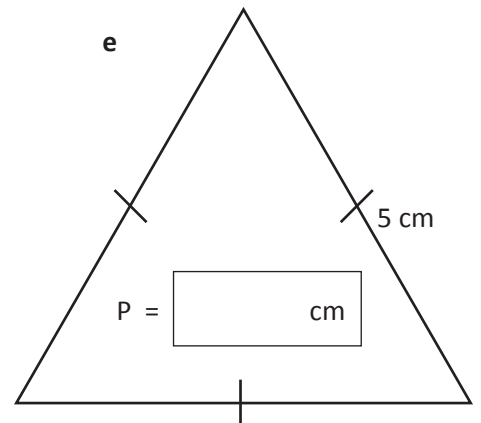
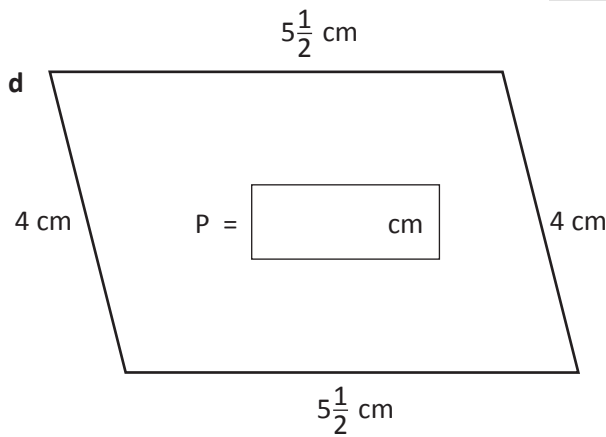
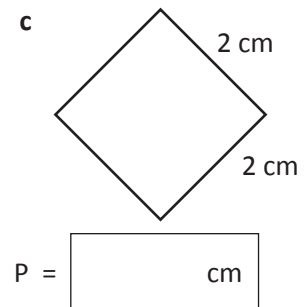
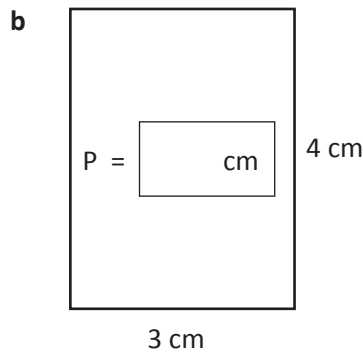
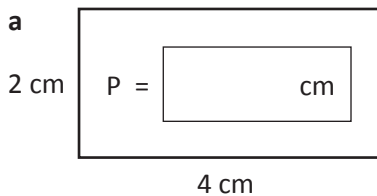

Do you need to measure every side?  
Is there a faster way of doing it?



**THINK**

# Perimeter – measure perimeters

We can find the perimeter of squares and rectangles without measuring every side.

This rectangle has 2 sides measuring 2.5 cm and 2 sides measuring 4 cm.

$$(4 + 4) + (2.5 + 2.5) = 8 + 5 = 13 \quad \text{Perimeter is } 2L + 2W$$

Another way to organise this is  $2 \times (L + W)$

Squares are even easier:  $4 \times L$

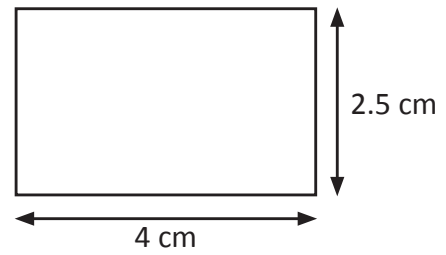

**3** Use a shortcut method to work out the perimeter of:

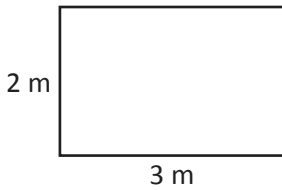

**a**  $P =$

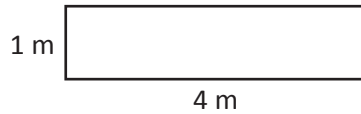

**b**  $P =$

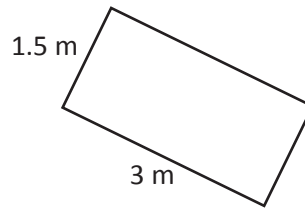

**c**  $P =$

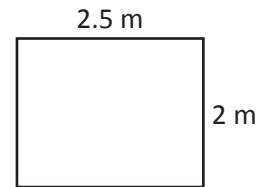

**d**  $P =$

**4** Find the perimeter of rectangles with the following dimensions:

Length	Width	Perimeter
6 cm	2.2 cm	
12.5 mm	4 mm	
5.54 m	3.56 m	
150 cm	1.3 m	

**5** Circle the correct perimeter for these rectangles:

**a** Length 12 cm, Width 8 cm

32 cm     40 cm     20 cm

**b** Length 14 mm, Width 12 mm

26 mm     52 mm     40 mm

**c** Length 8.5 cm, Width 2.7 cm

22.4 cm     112 cm     11.2 cm

**d** Length 10.2 cm, Width 8.4 cm

85.68 cm     36 cm     37.2 cm

**e** Length 22 mm, Width 11 mm

6.6 cm     33 mm     60 mm

# Perimeter – perimeters of composite shapes

1 Work out the perimeter of these composite shapes\* by adding the length of the sides:

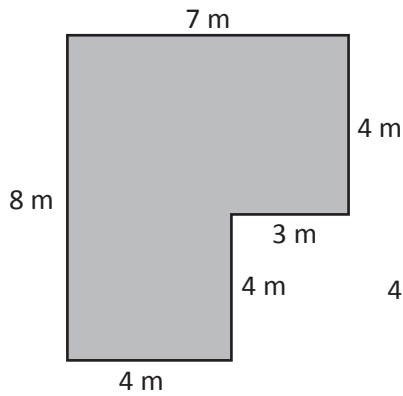

a  $P =$

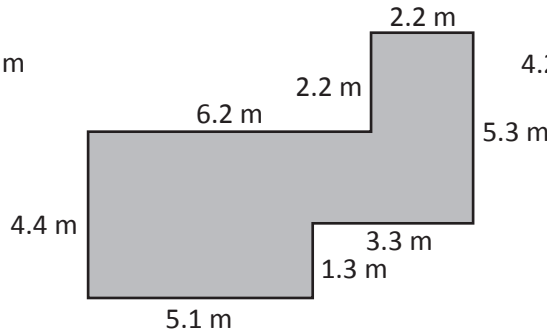

b  $P =$

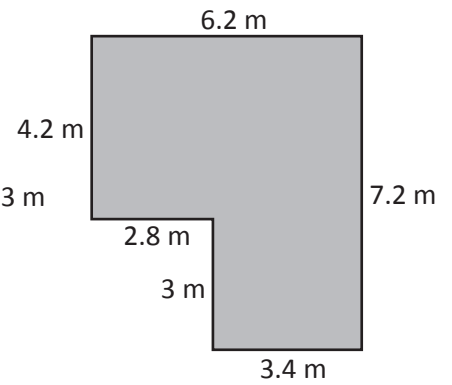

c  $P =$

\*Not drawn to scale.

2 These shapes\* are symmetrical. Use this knowledge to help you find their perimeters:

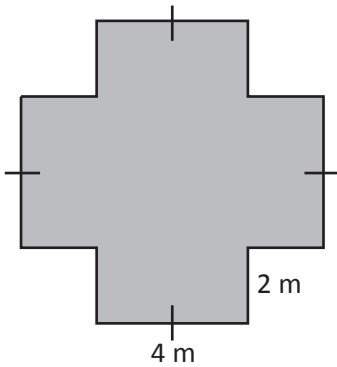

a  $P =$

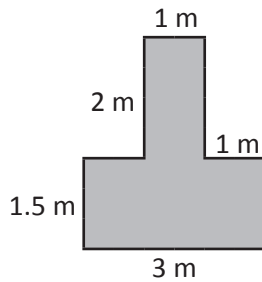

b  $P =$

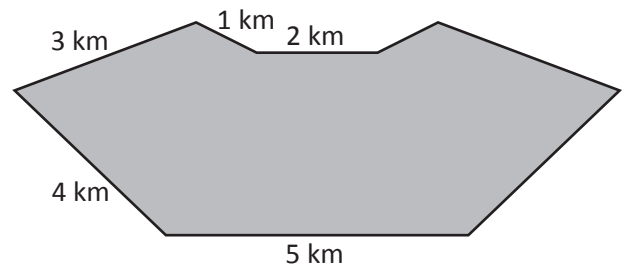

c  $P =$

\*Not drawn to scale.

3 Draw 3 different shapes on the 5 mm dot paper, each with a perimeter of 200 mm.

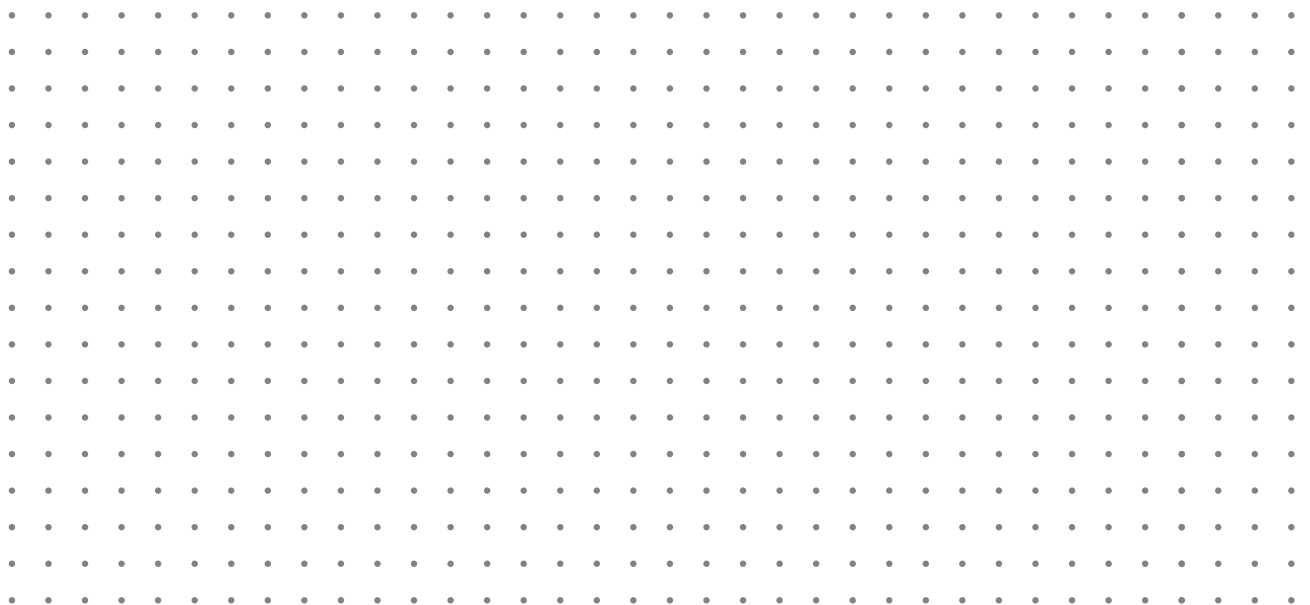

# Perimeter – perimeters of composite shapes

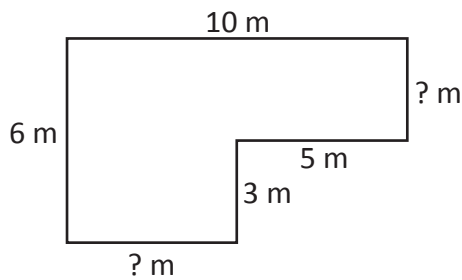

Look at this shape. Some of the measurements are missing. How do we work out the perimeter?

We use the information we have to help us fill in the gaps.

$$5\text{ m} + ?\text{ m} = 10\text{ m} \quad 10\text{ m} - 5\text{ m} = 5\text{ m}$$

$$3\text{ m} + ?\text{ m} = 6\text{ m} \quad 6\text{ m} - 3\text{ m} = 3\text{ m}$$

The perimeter of this shape is therefore 32 m.

4 Work out the perimeter of these shapes\* using the known measurements to guide you:

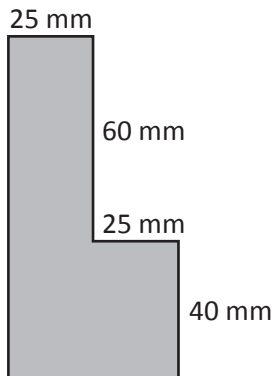

a  $P =$

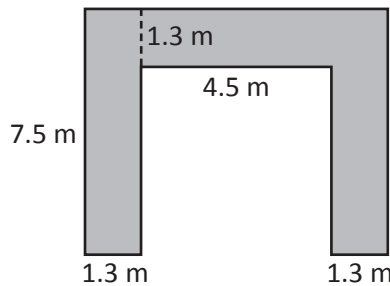

b  $P =$

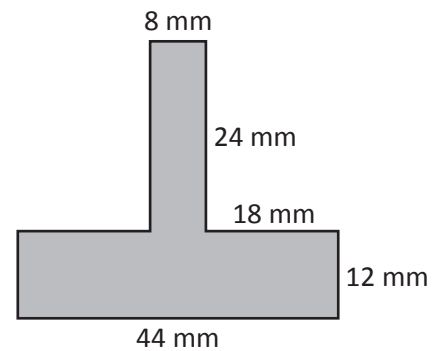

c  $P =$

\*Not drawn to scale.

5 What is the length of the dotted line in each shape\*?

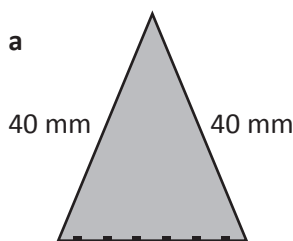

$P = 110\text{ mm}$

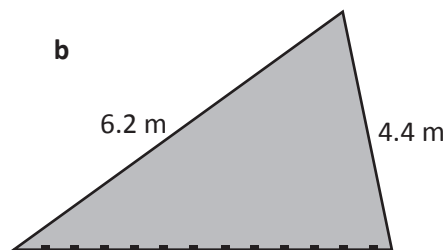

$P = 16.6\text{ m}$

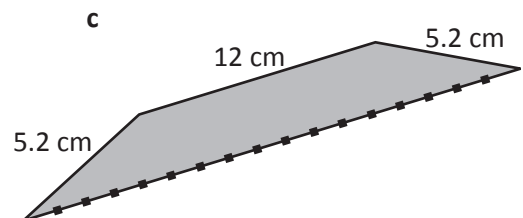

$P = 44\text{ cm}$

\*Not drawn to scale.

6 Find the mystery perimeters:

- a I have 4 sides.  
My opposing sides are equal.  
One of my sides is 8 cm in length.  
Another is 4 cm.  
What is my perimeter?

- b I have 6 sides.  
All my sides are equal.  
One of my sides is 5.62 mm.  
What is my perimeter?

- c I am a regular octagon.  
6 of my sides total 12.6 cm in length.  
What is my perimeter?

# Perimeter – perimeters of composite shapes

7 Using block letters, write your name on this 5 mm dot paper. What is the perimeter of your name?

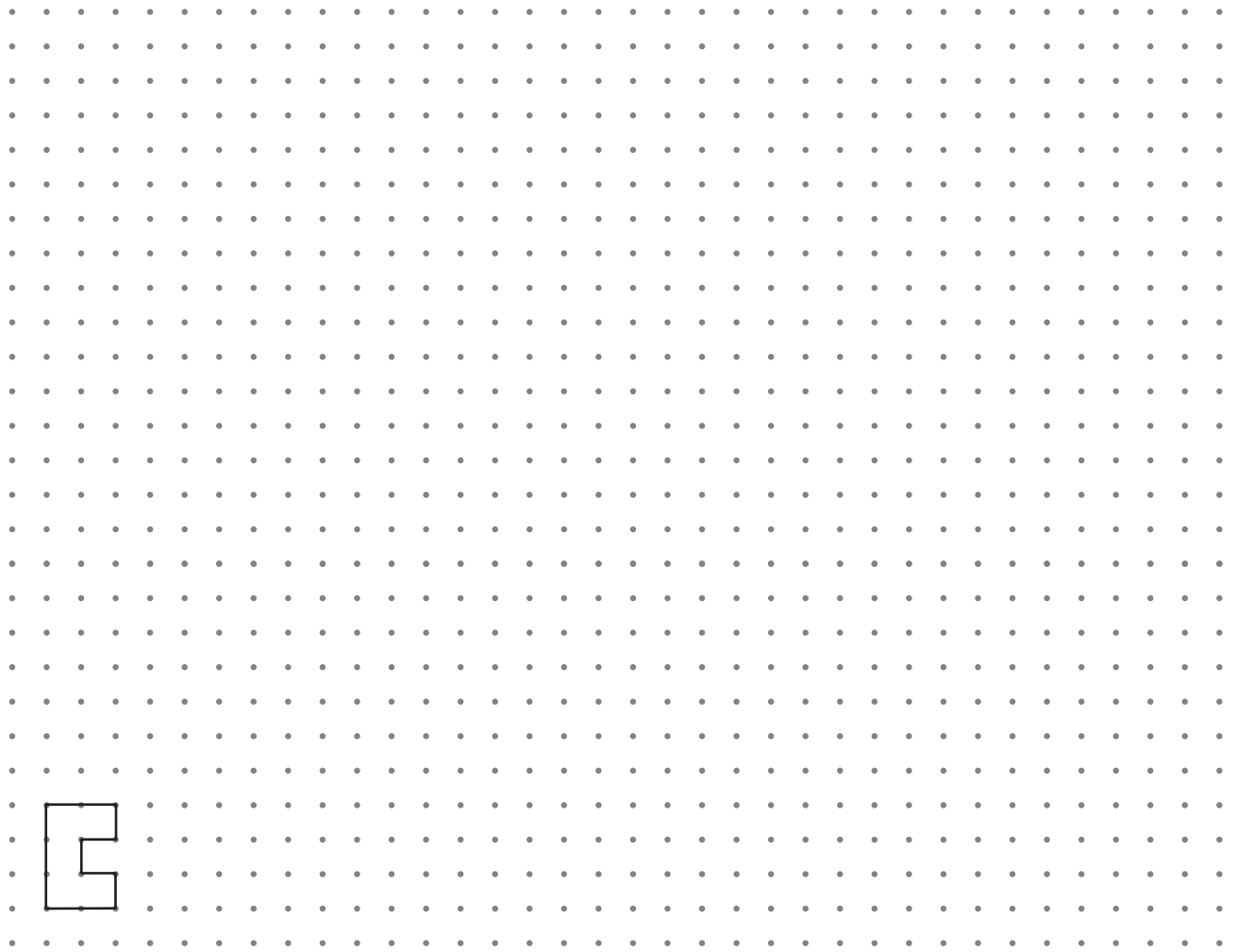

8 Find 3 things that are roughly twice as long as they are wide. Calculate their perimeter:



# Perimeter – circumference

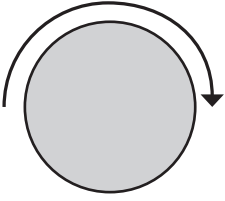

The perimeter of a circle is called its circumference.  
We have to measure circumferences differently to other shapes as there are no straight lines to help us.

- 1** One way to measure the circumference is to roll the object in a straight line and to then measure the length of this line.



Choose 5 objects to measure in this way. Estimate before you measure and record your findings in the table below. It is helpful to mark the object itself so you know when to stop.

	Object	Estimate	Measurement	Diameter
1				
2				
3				
4				
5				

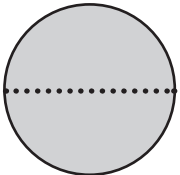

That strategy is not very practical for large objects. How else can we find the circumference?

We can use the diameter to help us. The diameter is a straight line that runs through a circle, passing through the midpoint.

- 2** Measure the diameters of the 5 objects you measured in Activity 1. Compare each diameter with its circumference. What do you notice? Is there a pattern going on?

- 3** Now use your calculator and divide each circumference by its diameter. What does that tell you? Write a statement about what you have found.





**Getting ready**

For this activity, you will need a partner, a tape measure or metre ruler and some string. You'll also need to work outside or in a large space. You are going to explore the relationship between the circumference of a circle and its radius.

The radius of a circle is the distance from the midpoint to the edge.

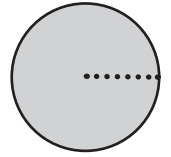

**What to do**

Follow these directions:

- 1 Cut a length of string that is 4 m long. This piece of string will be your radius.
- 2 One of you stands still in the middle of the space (anchor) while the other (walker) stretches the string out.
- 3 The walker then walks slowly round the anchor with the string stretched out. Both count the steps the walker takes.

How many steps did he or she take?

Compare the radius (4 m) with the number of steps.

What do you notice? Is there an approximate relationship?

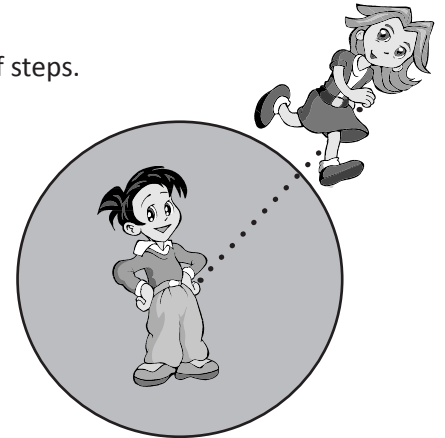

**What to do next**

Try the activity again but this time, fold your string in half so it is 2 m long.

How many steps did the walker take this time?

How does this radius compare with the number of steps?

Choose another length and try that out. You could make your string 1 m or join it with another team's to make an 8 m length.

What would you say is the relationship between the circumference of a circle and its radius? Can you predict what the circumference of a circle with a 20 m radius might be?



What to do

Solve these perimeter puzzles:

- a** Look at this isosceles triangle. The base measures 3 m.  
The perimeter of the triangle is 11 m.

What is the length of one of the other sides?

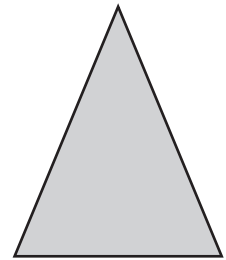

- b** An equilateral triangle has a perimeter of 15.9 mm. How long is each side?

Each side is  long.

- c** Farmer Joe needs to re-fence one of his paddocks. The perimeter of the paddock is 144 m. The paddock is twice as long as it is wide.

What is its length? What is its width?

L =

W =



- d** A square piece of paper is divided in half as shown.  
If the perimeter of one of the halves is 36 cm,  
what was the perimeter of the original square?

P =

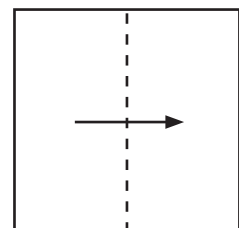

# Area – square units

Area is the amount of space a shape covers. It is a 2D measurement.  
We measure area in square units. For small areas we use square centimetres.

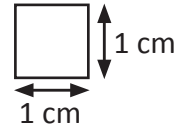

1 What is the area of each shaded shape? Each square has an area of  $1 \text{ cm}^2$ .

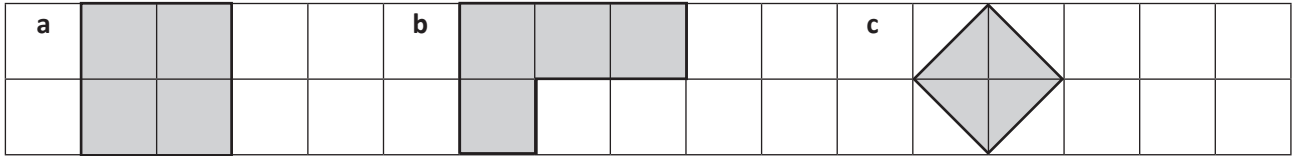

Area =   $\text{cm}^2$

Area =   $\text{cm}^2$

Area =   $\text{cm}^2$

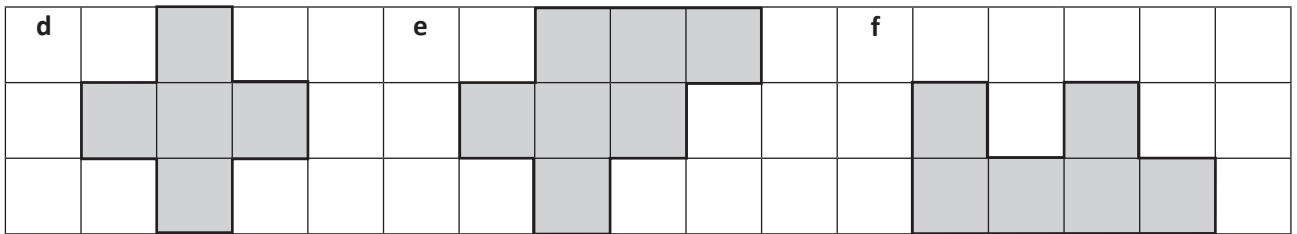

Area =   $\text{cm}^2$

Area =   $\text{cm}^2$

Area =   $\text{cm}^2$

2 How many different shapes can you make that have an area of  $6 \text{ cm}^2$ ?

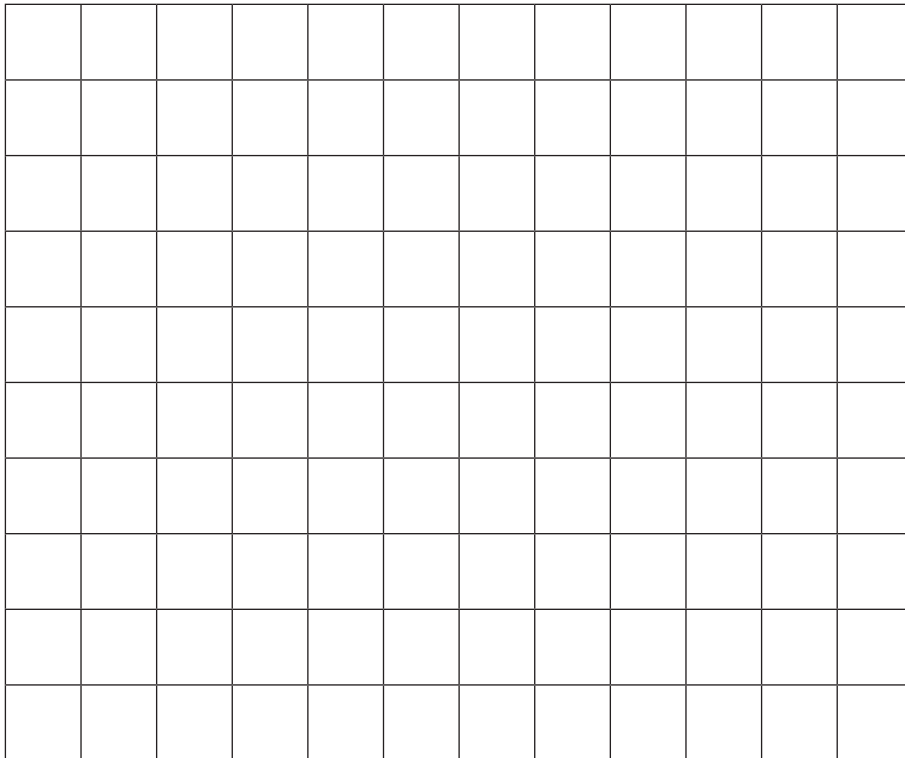

Do you need to use whole squares? How could you make an area of  $6 \text{ cm}^2$  using part squares?



**THINK**

Choose another area and see how many of those shapes you can make.

# Area – square units

For larger areas such as a tennis court we use square metres ( $m^2$ )  
 For even larger areas such as countries, we use square kilometres.  
 A square kilometre is 1 000 000  $m^2$ .

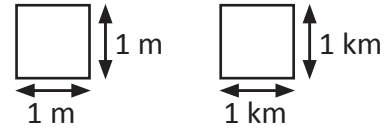

### 3 How much space do you predict 1 $m^2$ would take up?

- a Work in a small group and use chalk or string to mark your prediction on the ground. Use a ruler to measure it out. Is it smaller or larger than you imagined?

---

- b Now, how many people do you think could fit in your square? They must all be able to stand with both feet on the ground and inside the lines. Test it out. Record your prediction and the result.

Estimate =  Measurement =

We also use hectares (ha) to measure area.  
 These are larger than square metres but smaller than square kilometres. We use them for measuring spaces such as farms or parks.

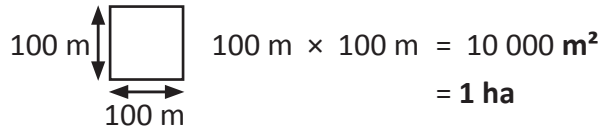

### 4 Convert the following:

- |                |                            |                |                            |                 |                            |
|----------------|----------------------------|----------------|----------------------------|-----------------|----------------------------|
| a 10 000 $m^2$ | <input type="text"/> ha    | b 80 000 $m^2$ | <input type="text"/> ha    | c 30 000 $m^2$  | <input type="text"/> ha    |
| d 20 000 $m^2$ | <input type="text"/> ha    | e 50 000 $m^2$ | <input type="text"/> ha    | f 110 000 $m^2$ | <input type="text"/> ha    |
| g 4 ha         | <input type="text"/> $m^2$ | h 9 ha         | <input type="text"/> $m^2$ | i 12 ha         | <input type="text"/> $m^2$ |
| j 5 000 $m^2$  | <input type="text"/> ha    | k 15 000 $m^2$ | <input type="text"/> ha    | l 7 500 $m^2$   | <input type="text"/> ha    |

### 5 Would you choose $cm^2$ , $m^2$ , ha or $km^2$ to measure the area of the following?

- |               |                      |                         |                      |
|---------------|----------------------|-------------------------|----------------------|
| a This page   | <input type="text"/> | b Egypt                 | <input type="text"/> |
| c A farm      | <input type="text"/> | d A mobile phone screen | <input type="text"/> |
| e A city park | <input type="text"/> | f A national park       | <input type="text"/> |
| g A cd cover  | <input type="text"/> | h A football stadium    | <input type="text"/> |

# Area – find area using formulae

We can use this formula to find the area of rectangles.

$$\text{Area} = \text{Length} \times \text{Width}$$

$$\text{Area} = 4 \text{ cm} \times 2 \text{ cm} = 8 \text{ cm}^2$$

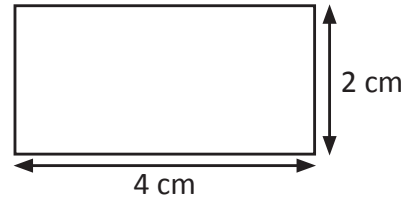

1 Use the formula  $A = L \times W$  to help you find the areas\* of:

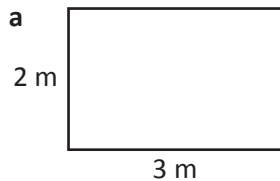

$$A = \boxed{\phantom{000}}$$

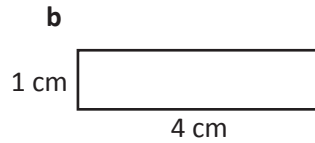

$$A = \boxed{\phantom{000}}$$

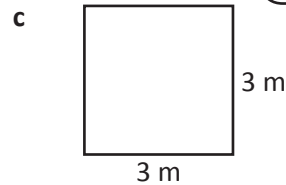

$$A = \boxed{\phantom{000}}$$

\*Not drawn to scale.

This saves us from ruling up grids and counting squares.



2 Find the area of the following:

a A rectangle measuring 8 cm × 5 cm

b A box measuring 30 cm × 7 cm

c A pool measuring 25 m × 10 m

d A phone measuring 4.5 cm × 10 cm

e A book measuring 35 cm × 12 cm

f A field measuring 60 m × 25 m

g A town square with 4 sides of 10 m

h A rug measuring 10.2 m × 3.4 m

3 Answer these area word problems:

a Marianne wants to buy new carpet for her bedroom. Her room is 3 m × 4 m and the carpet she wants costs \$50 per m<sup>2</sup>. How much will the new carpet cost her?

b A book is 12 cm longer than it is wide. If it is 10 cm wide, what is the area of the book?

c A garden has an area of 35 m<sup>2</sup>. If the garden is 7 m long, what is its width?

d The area of a rectangle is 48 cm<sup>2</sup>. What might be the length and width?  
Come up with 2 options:

Option 1 L =  W =

Option 2 L =  W =

# Area – find area using formulae

Each triangle is half of a rectangle.  
To find the area of a triangle, we find the area of the rectangle and then divide by two.

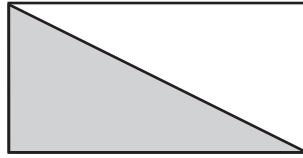

Rectangle =  $8 \text{ cm} \times 4 \text{ cm} = 32 \text{ cm}^2$

Triangle =  $32 \text{ cm}^2 \div 2 = 16 \text{ cm}^2$

The formula for this is:

$\frac{1}{2} \text{ Base} \times \text{Height}$

4 Find the area of the shaded triangles inside the rectangles\*:

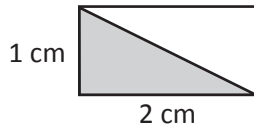

a Area =   $\text{cm}^2$

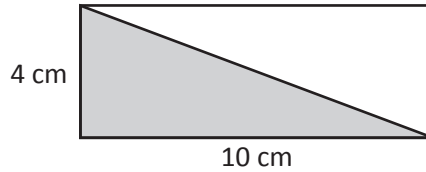

b Area =   $\text{cm}^2$

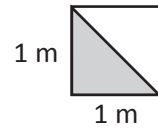

c Area =   $\text{m}^2$

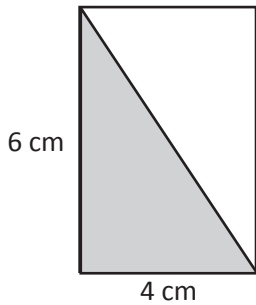

d Area =   $\text{cm}^2$

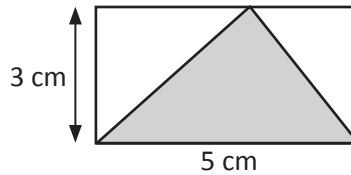

e Area =   $\text{cm}^2$

This works for all triangles – right angled, isosceles, equilateral and scalene. One formula fits all!

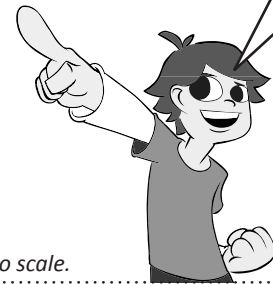

\*Not drawn to scale.

5 Find the area of these triangles\* using the formula  $\frac{1}{2} \text{ Base} \times \text{Height}$ :

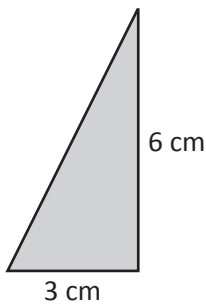

a Area =   $\text{cm}^2$

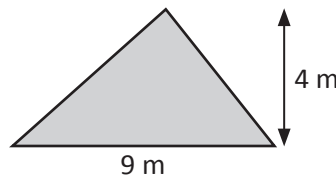

b Area =   $\text{cm}^2$

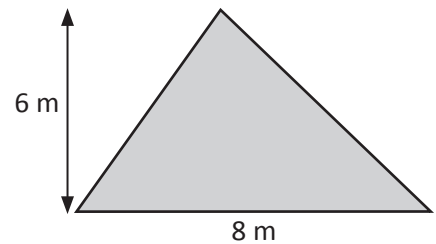

c Area =   $\text{m}^2$

d A triangle with a base of 12 cm and height of 7 cm

e A triangle with a base of 17 m and a height of 14 m

f A triangle with a base of 10.2 m and a height of 9 m

\*Not drawn to scale.

# Area – find area of irregular and composite shapes

Not all shapes are regular triangles or rectangles. We have to find ways to measure the areas of composite and other irregular shapes as well.

One way is to break the shape into known shapes, find these areas, and then add them together.

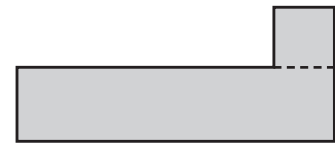

**1** Find the area of these irregular shapes\*:

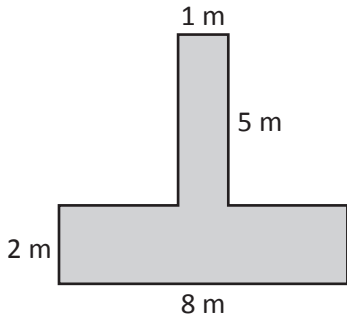

a

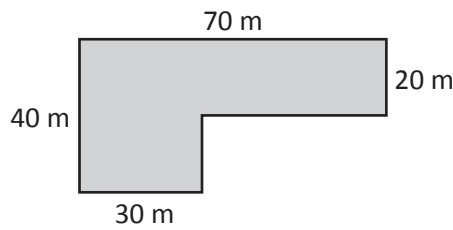

b

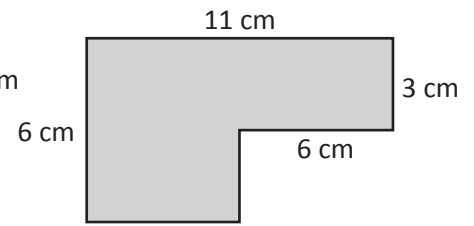

c

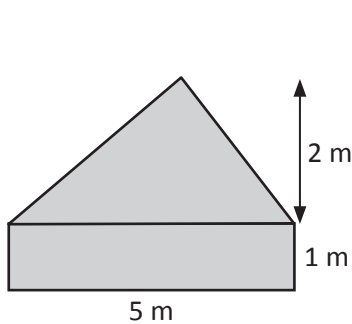

d

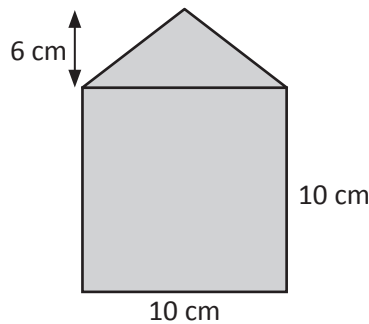

e

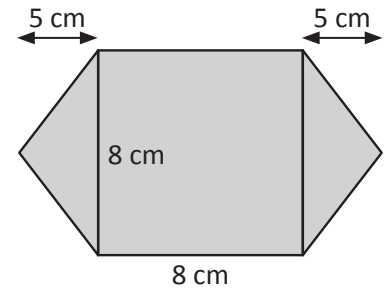

f

**2** Construct your own composite shape with an area of  $20 \text{ cm}^2$ . Label the lengths of the sides.

# Area – find area of irregular and composite shapes

There is no exact way to find the area of some irregular shapes.  
We can use grids to estimate.  
The smaller the squares on the grid, the closer the estimate.

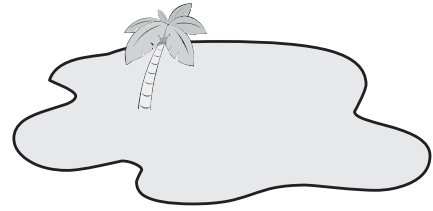

3 Estimate the area of these shapes:

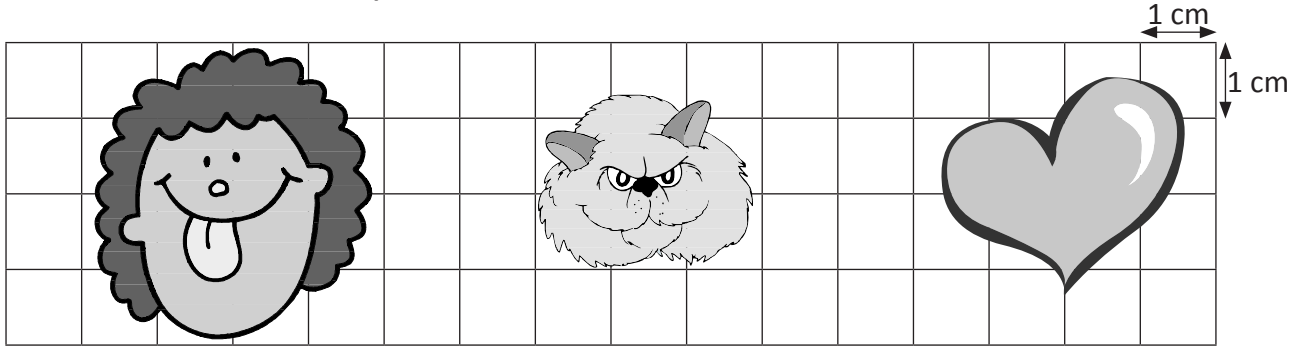

a  $A = \underline{\hspace{2cm}} \text{ cm}^2$

b  $A = \underline{\hspace{2cm}} \text{ cm}^2$

c  $A = \underline{\hspace{2cm}} \text{ cm}^2$

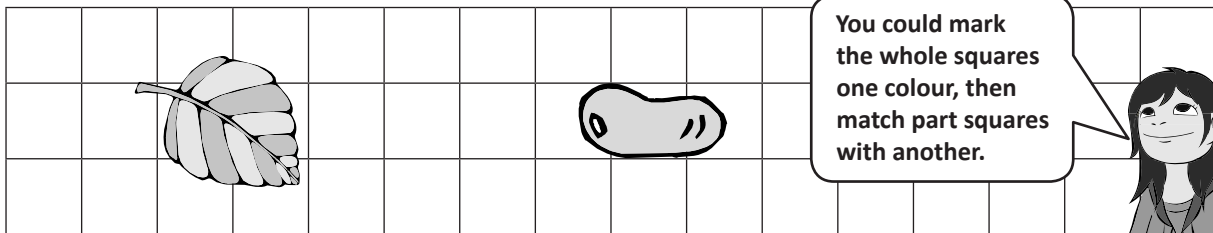

d  $A = \underline{\hspace{2cm}} \text{ cm}^2$

e  $A = \underline{\hspace{2cm}} \text{ cm}^2$



4 On the grid on the right, draw an irregular shape for each area amount:

a  $800 \text{ m}^2$

b  $1\,200 \text{ m}^2$

c  $2\,500 \text{ m}^2$

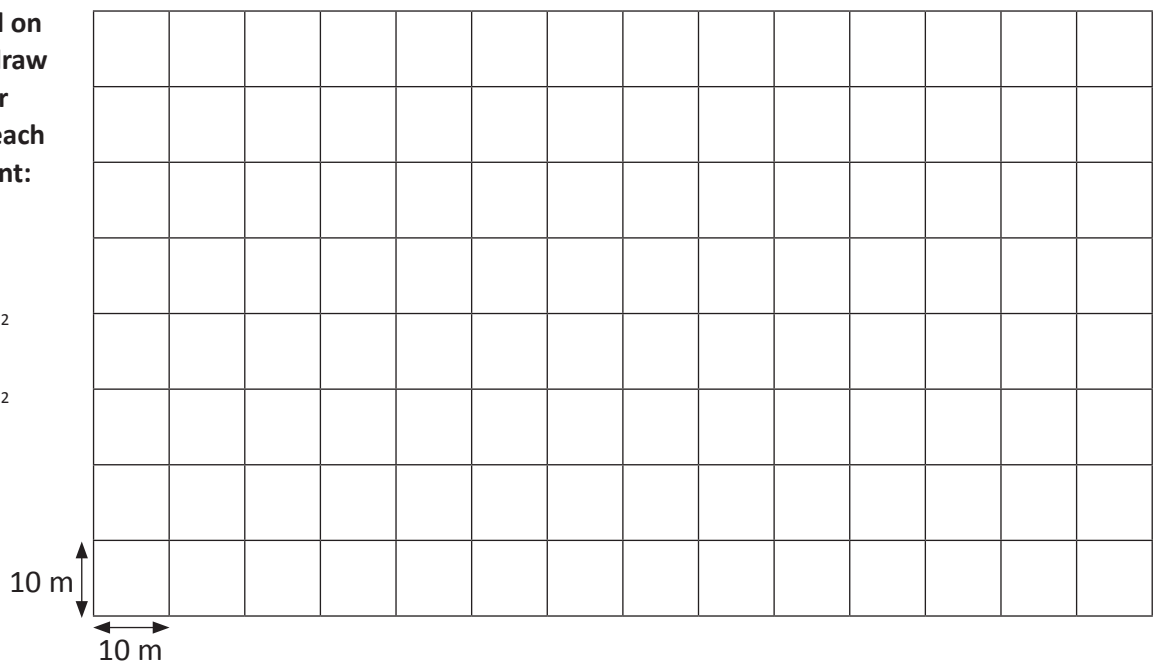



# Area – area and perimeter

Do shapes with the same area have the same perimeter?

No.

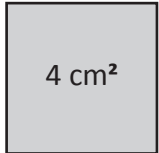
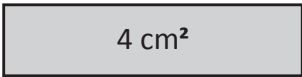

- 1 Draw some shapes with an area of  $12 \text{ cm}^2$ . Measure and record their perimeters in the table below. What do you find?

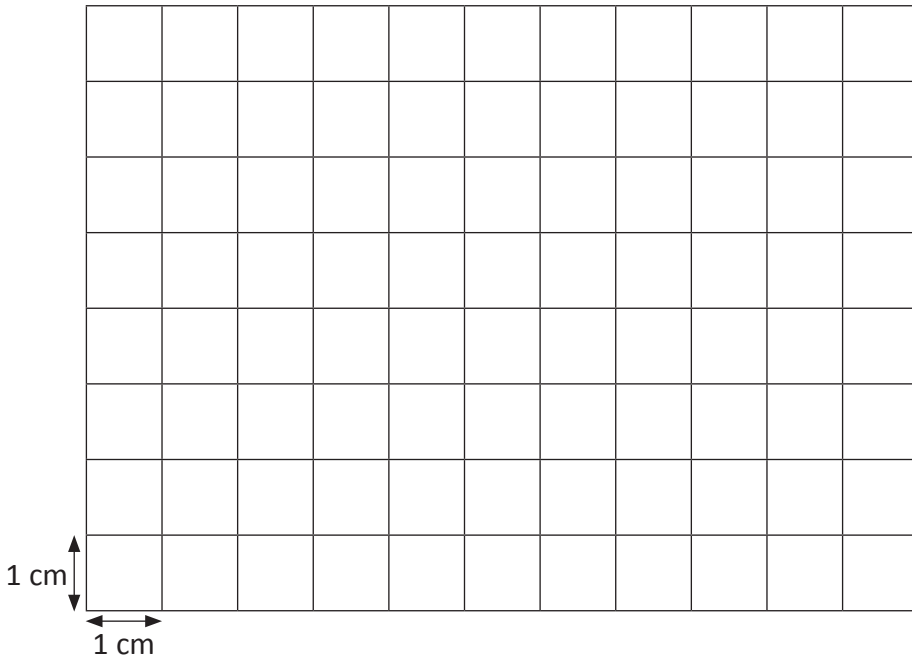

Length	Width	Area

- 2 This time, use a perimeter of 20 cm as your starting point. Create different shapes with a perimeter of 20 cm and calculate their area.

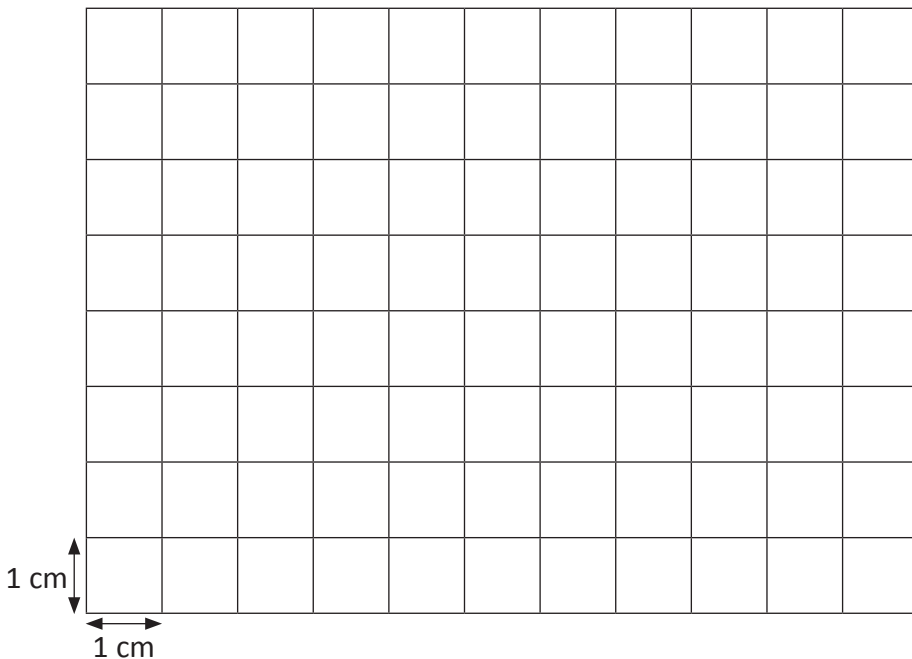

## Area – area and perimeter

**3** Solve these problems. Show your working out:

a The perimeter of a square is 48 cm. What is its area?

b The perimeter of a rectangle is 30 cm. If the rectangle is 4 times as long as it is wide, what is the area of the rectangle?

c The area of a square is 36 m<sup>2</sup>. What is its perimeter?

---

**4** The desks in your classroom are 1 m long and 50 cm wide and seat 2 students. Your teacher would like you to put them in groups of 3 so that 6 students can sit comfortably. Draw at least 2 different options and calculate the perimeter and area of each option.

Which is your preferred option? Why?



Shakira has had it with her brothers wrecking her stuff and decides to fence off her own area of the family room using the sofa cushions. There are 8 cushions, each 50 cm long. If she uses two of the walls as part of her boundary, what is the largest area she can make for herself that is brother-free?

Show her best option below:



.....

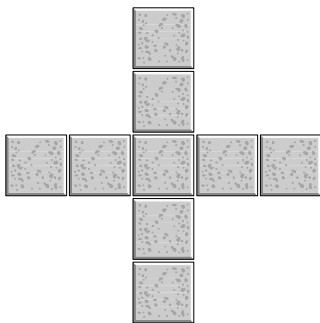

The garden path on the left is made up of 9 identical squares.

a If the perimeter of the path is 20 m, what is its area?

b What about if the perimeter was 60 m? What would then be the area?

c If the area of the path is 36 m<sup>2</sup>, what is its perimeter?

.....

How many steps are involved in this problem? Maybe I need to work out the area of each wall first.



**THINK**

Paige wants to paint the walls of her room purple. Her parents say she can do it but only if the paint costs less than \$250. Paige has found some purple paint going cheap at \$55 per 4 litre pot. Each pot will cover 9 m<sup>2</sup>.

Her bedroom is 3 m × 4 m and each wall is 2.5 m high. She has one window with an area of 1 m<sup>2</sup> that doesn't need to be painted. The ceiling is covered in silver stars already so she won't paint that either.

Can she do it? Show your working out.



Four African animals have been stolen by smugglers. Fortunately you intercepted them and can return the animals to their natural habitat.

You have four enclosures in which to transport the animals safely. You know the areas of each side of the box but you don't know the lengths, heights or widths. You need to select the right one for each animal.

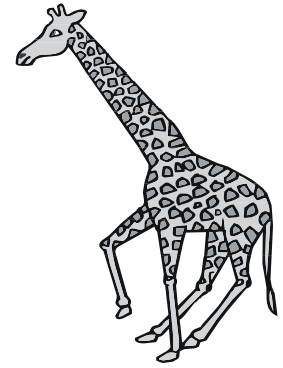

Follow these directions:

- 1 Look at the approximate dimensions of the animals.
- 2 Now look at the boxes. The area of each side is specified. Knowing this, what could the height, length and width of each side be? Label them.
- 3 Join the animal to the box you think would fit it best.

Guess, check and improve would be a useful strategy here.



**THINK**

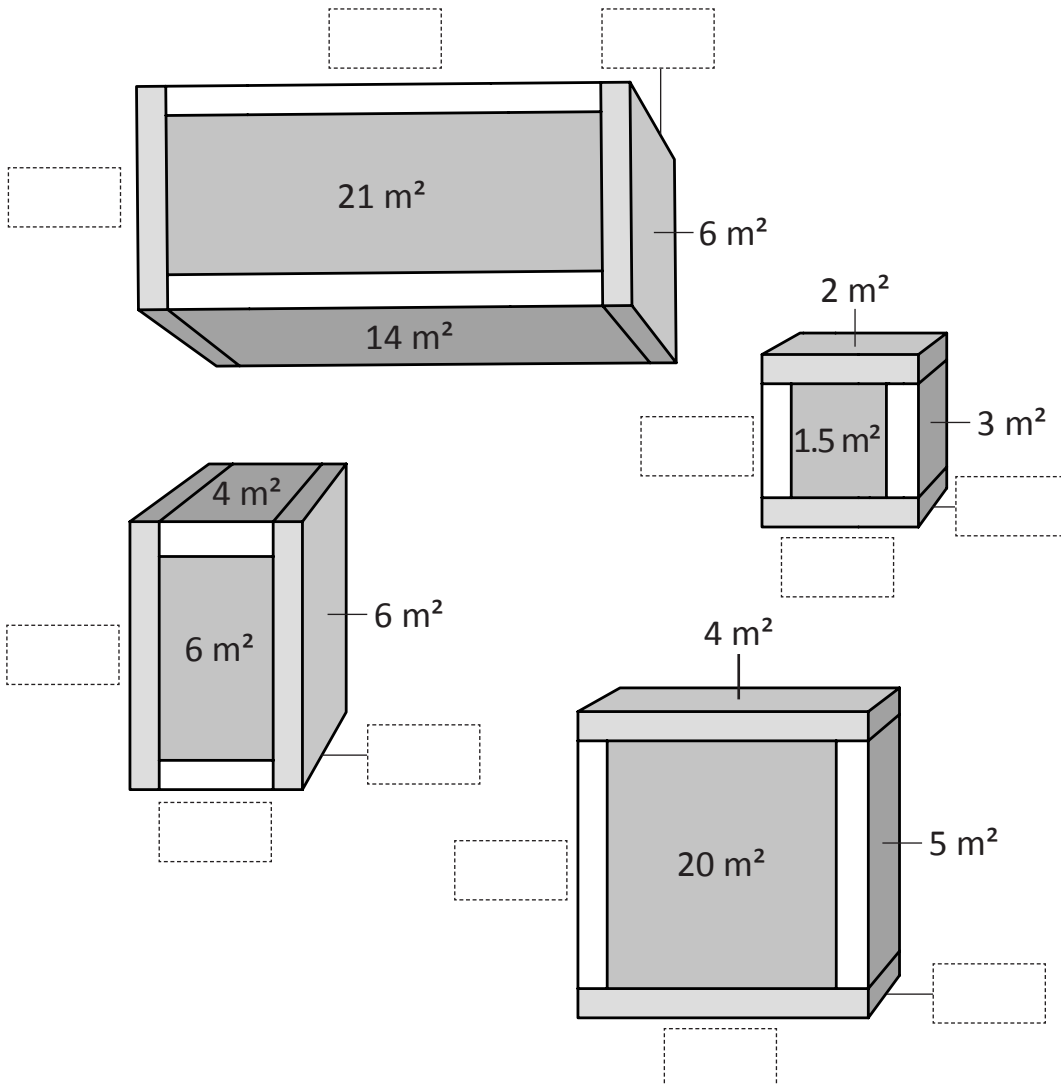

**Giraffe**

H – 5 m  
L – 4 m  
W – 1 m

**Elephant**

H – 3 m  
L – 7 m  
W – 2 m

**Hippo**

H – 3 m  
L – 2 m  
W – 2 m

**Lion**

H – 1.5 m  
L – 1 m  
W – 2 m

# Scale and distance – scale drawings

We use scale drawings to represent larger measurements or objects.

Maps and floor plans are good examples of when we use scale in real life.

We use one measurement to represent another, like this:  $1 \text{ cm} = 5 \text{ km}$

- 1 If the length of each cell on the square grid to the right represents 3 km, how long is each line?

a		<input type="text" value="km"/>
b		<input type="text" value="km"/>
c		<input type="text" value="km"/>
d		<input type="text" value="km"/>
e		<input type="text" value="km"/>

- 2 What about if each cell represents 20 cm?

a       b       c       d       e

- 3 If the length of (a) was 1.5 m, what would each cell represent in cm?

- 4 If the length of (d) was 125 mm, what would each cell represent in mm?

- 5 Using the map of the showground below, work out how far apart in real life these places are. You must follow the grey paths.

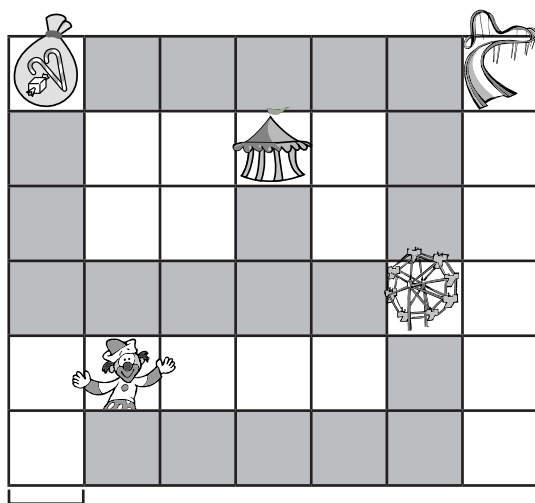

1 cm represents 50 m

- a From the roller coaster to the show bags.
- b From the clowns to the big top.
- c From the Ferris wheel to the big top.
- d You start off at the Ferris wheel, then go to the roller coaster. You are now feeling a bit queasy and sit down in the big top for a bit. You decide you are feeling better and go on a show bag shopping spree. How far have you walked?
- e Show your journey on the map.

# Scale and distance – scale drawings

**6** Now design your own map:

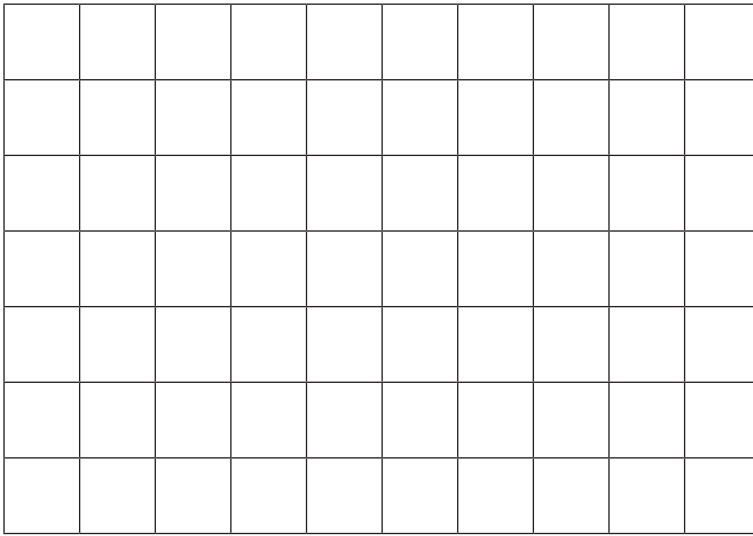

1 cm represents \_\_\_\_\_

- a Draw 5 places on the map.
- b Decide on a scale.
- c Write 3 problems on another piece of paper for a friend to solve.
- d Ask for feedback from your friend. Do they have enough information to answer your questions?
- e Make changes as needed.

**7** Look at the floor plan of the apartment below. Answer the following questions:

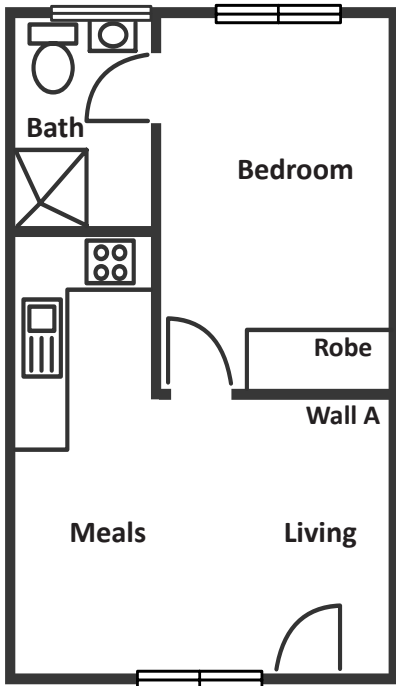

- a What is the scale?  
\_\_\_\_\_
- b What is the perimeter of the apartment?  
\_\_\_\_\_
- c What is the perimeter of the bedroom?  
\_\_\_\_\_
- d What is the length and width of the bathroom?  
\_\_\_\_\_
- e You want to buy a plasma TV that takes up  $\frac{1}{2}$  the length of Wall A. How long will it be?  
\_\_\_\_\_
- f If your plasma TV is 0.75 m high, what will its perimeter be?  
\_\_\_\_\_
- g Is this a big apartment?  
\_\_\_\_\_
- h Explain your thinking.  
\_\_\_\_\_  
\_\_\_\_\_

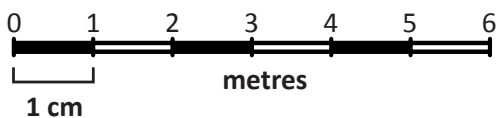

# Scale and distance – maps

We use maps to locate places and to find the distance between them. Usually we use a scale to work out distances, though sometimes they are marked on the map.

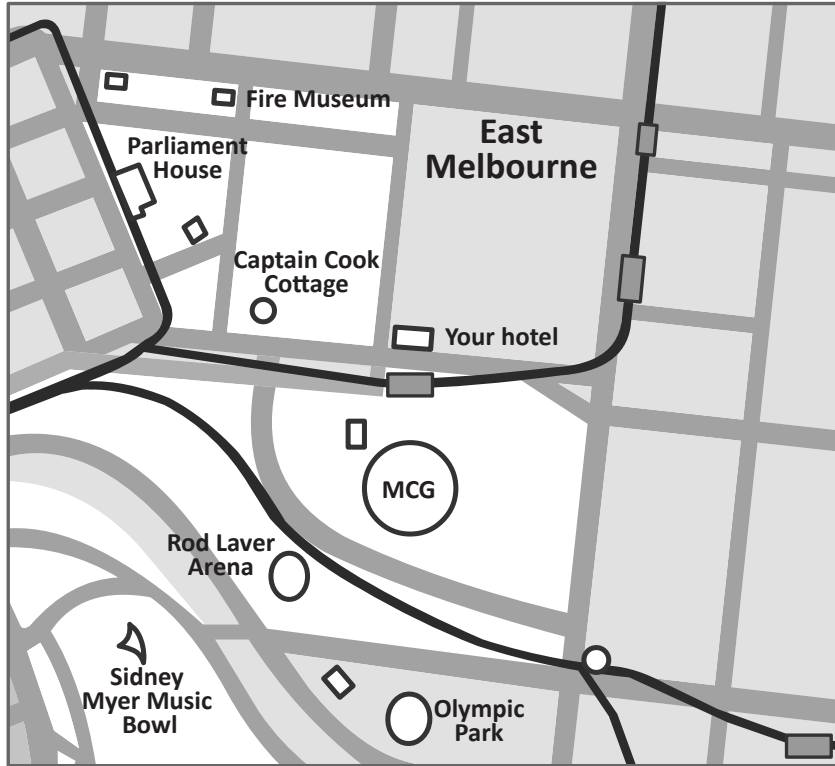

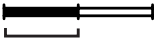
SCALE:  
  
 1 cm = 1 000 m

**1** You have won an all expenses paid luxury weekend in Melbourne, Australia. Accommodation in a fancy hotel, sporting tickets, spending money for a shopping spree – the whole works. All you need to do is to get yourself around. Using the map, work out:

a As the crow flies, how far is it from your hotel to Olympic Park?

b After watching an AFL match at the Melbourne Cricket Ground (MCG), you are going to catch Kylie Minogue in concert at the Rod Laver Arena. How far is it between them?

c Would you walk to the concert or hail a taxi? Why?  
 \_\_\_\_\_

d The next day you decide to get cultural and visit some museums. Come on, stop complaining, it's good for you. You'll head off from your hotel, have a look at Captain Cook's Cottage, visit the Fire Museum and then end up at Parliament House. Trace the route on the map, then measure the distance.

e The answer is 1.5 km. What could be the question?  
 \_\_\_\_\_

# Scale and distance – maps

2 Use the map below to answer the following questions:

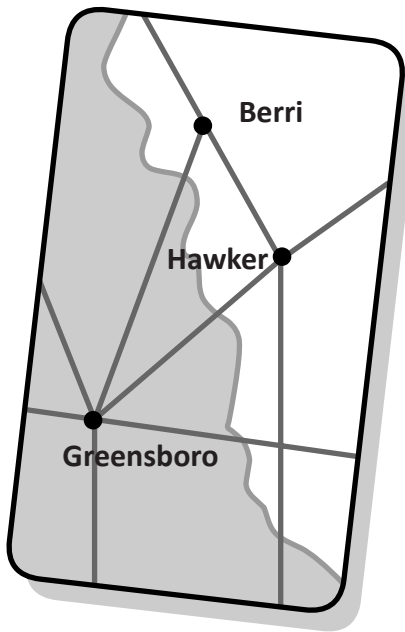

SCALE:

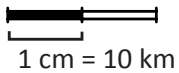

a What is the distance between Berri and Hawker?

b If you travelled from Greensboro to Berri via Hawker, what distance would you travel?

c Put a new town on the map that is 15 km from Greensboro. It must sit on an existing road. Choose a name for your town.

---

d Write a word problem for a friend to solve using your new town.

---



---



---



---

3 Look at the road sign below. It shows the distances of five towns from your current position.

a How far is Sun Hill from Springfield?

b Which town is closer to Erinsborough, Springfield or Walford?

c What is the distance between Sun Hill and Summer Bay?

d Your parents have hired a car for the journey. The car costs are as follows:

- \$68 per day – base rate
- the first 200 km of the journey are free
- 50c per kilometre thereafter.

How much will it cost you to drive to Summer Bay and back? Assume the trip will take 2 days.

Walford	12 km
Sun Hill	27 km
Erinsborough	145 km
Springfield	355 km
Summer Bay	455 km



# Scale and distance – speed, time and distance

Speed can be measured in kilometres per hour.

60 km per hour means that it took 1 hour to travel 60 km and is written 60 km/h.

We divide the distance travelled by the time taken to find the average speed.

## 1 What speed am I travelling if I cover:

a 120 km in 2 hours

b 320 km in 8 hours

c 30 km in 1 hour

d 130 km in 2 hours

e 480 km in 6 hours

f 45 km in 1 hour

## 2 Look at the speedometers and record the speeds below:

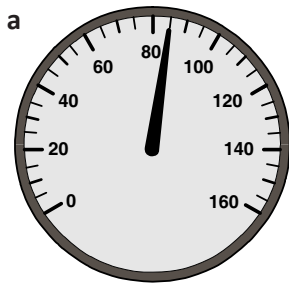
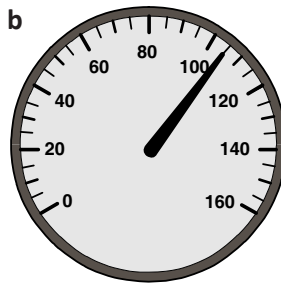
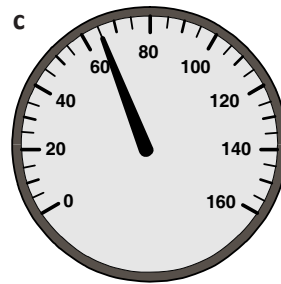
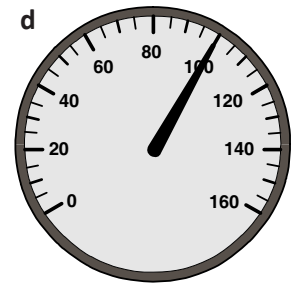
 km/h

 km/h

 km/h

 km/h

## 3 The odometers below show the length of a journey. Calculate the distance travelled for each journey and how long it would have taken if the car had been travelling at 80 km/h. A calculator could help you find the differences between the start (top row) and the end (bottom row) of the journey.

a

Distance

Time

b

Distance

Time

c

Distance

Time

d

Distance

Time

# Scale and distance – speed, time and distance

## 4 Answer the following word problems:

a A car travels at an average speed of 75 km/h. How far would it travel in 5 hours?

b A train trip totals 450 km. If the trip takes 9 hours, what is the train's average speed?

c A plane flies 600 km in  $1\frac{1}{2}$  hours. What is its average speed per hour?

d Muhammed walks 24 km in  $1\frac{1}{2}$  hours. What is his average speed per hour?

e A miniature train travels 100 km in  $2\frac{1}{2}$  hours. What is its average speed per hour?

$1\frac{1}{2}$  hours can be broken into three 30 minute segments. How far does the plane travel in 30 minutes? How many lots of 30 minutes are in 1 hour?



**DISCOVER**

## 5 Look at the snail trail below:

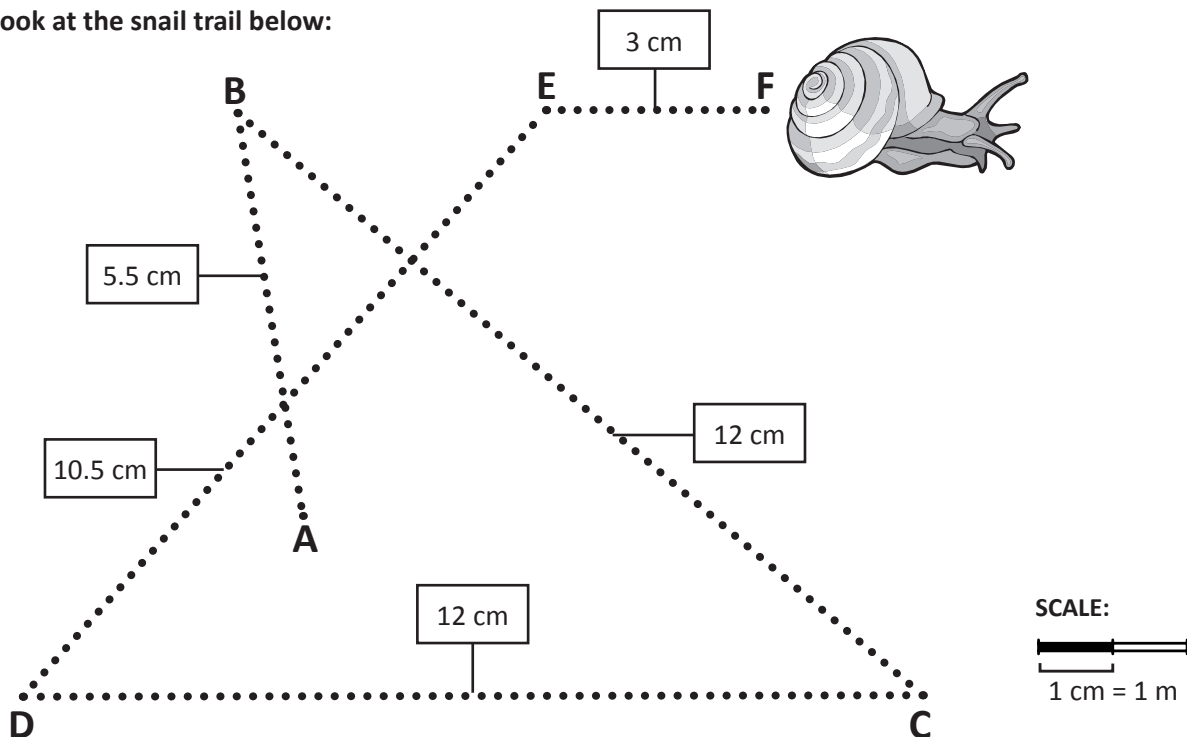

a If it took the snail 2 hours to make the trail, what was its average speed per hour? Express your answer in metres/h.

b The snail made a mad dash from point B to C to get away from a hungry looking bird and covered the distance in 15 mins. What was its speed for that stretch?



All measurements are in km.



Hmm, if I get a decimal such as 0.54, it is 0.54 of 60 mins, not 100. I could round this to 0.5, which is 30 mins.



You are planning a European holiday. You will travel at an average speed of 80 km/h. At this speed, what is the driving time between the following distances? Use rounding and estimation to help, you don't need to be absolutely precise.

- a Naples to Rome?
- b Copenhagen to Vienna?
- c Marseilles to Rome?
- d Milan to Lisbon?

You are now in Vienna and want to make it to Euro Disney in Paris as quickly as you can. Fortunately you are travelling through Germany and can take advantage of the autobahn and its unlimited speed limit.

If you travel the distance in just under  $8\frac{1}{2}$  hours, what was your average speed?



Getting ready

Car makers have developed two new cars that they believe are exceptionally environmentally friendly. They predict that the Stomper can travel 10 000 km on one tank of petrol and that the Styler can get 5 000 km from one tank. You have been asked to test drive one of the cars to test their prediction.

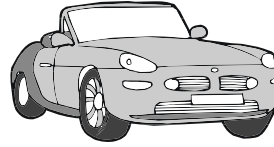

Styler

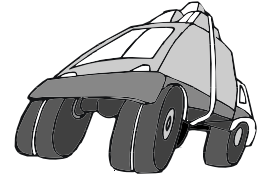

Stomper



What to do

Use a separate piece of paper.

Choose which car you would like to try out. You will need to plan your starting point then track your travels. Plan to cover approximately 1 000 km each day. You'll need an atlas or access to the internet and a program such as Google Maps to assist you. Before you start your journey, predict where you think you will end up.

You need to keep detailed records of the distances you have travelled. Use the table below to record your journey.

Car: \_\_\_\_\_ Distance to travel: \_\_\_\_\_

Day	Start	End	Distance

Where did you end up?  
Did you travel more distance or less than you predicted?

