



Year 7 Home Learning Booklet

Project Title: **Everyday Objects**

(Part 1)

Name:

Tutor:

Your teacher will refer to the page numbers when setting the work.
Each page should take approx. 30-45 minutes.

Autumn Term 2021-2022

"As practice makes perfect, I cannot but make progress; each drawing one makes, each painting one paints, is a step forward." - Vincent van Gogh

Who is Sir Michael Craig Martin?

To Do:

- ❑ Create an A4 poster filled with facts about Sir Michael Craig Martin. This worksheet is really helpful to follow as a **guide** to how much information to include. You can present your layout **however you like**, it does not have to be laid out like this.

This can be done on the computer or by hand.

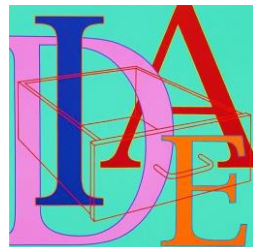

Name of Artist

In this section find out some **general information** about the artist, put it in your own words. Do not copy and paste.

e.g.
Born/Died?
Where did the artist live?
Where did the artist go to art school?

In this section talk about the **techniques and inspiration** the artist used in their work. Put it in your own words. Do not copy and paste.

e.g.
What media did the artist use?
What is the main style and characteristics of the artists work?
What influenced the artists work?

Insert a **picture** here by the artist

In this section **analyse** the artwork:
What can you see in the picture?
What medium has been used to create the artwork?
The colours are...
The lines/shapes/patterns are...
The medium has been applied using... (Thick strokes, loose strokes etc.)
The picture makes me feel...Why? (happy, sad, relaxed!)

Insert a **picture** here by the artist

In this section **analyse** the artwork:
What can you see in the picture?
What medium has been used to create the artwork?
The colours are...
The lines/shapes/patterns are...(bright, dull, dreary)
The medium has been applied using... (Thick strokes, loose strokes etc.)
The picture makes me feel...Why? (happy, sad, relaxed!)

Do not print out this sheet! It is a guide
For your layout in case you need inspiration.

Check out more of his images online, they are all really colourful.

Stick your colourful Sir Michael Craig Martin poster here

Drawing is hard! Sometimes you just can't figure it out. It seems no matter how hard you try, how intensely you look at a subject, your drawings look wrong.

Understanding drawing can be the key to both your artistic success and a creative mind. If you keep on thinking you can't draw, you won't.

As you try and draw something realistically and it starts to go 'wrong' your inner critic starts to rear its head.

Often drawings start off really well and you observe things accurately, it's only when you get to a perceived 'tricky' bit you start to question yourself.

The truth is you have probably started to 'make up' the rest of the drawing and have stopped observing, relying on what you think it looks like. In comes the inner critic and says: *"That doesn't look like a boat, give up now, it looks like a kid's done it"*

So what we have to do is stop labelling objects, and start to look more hypothetically.

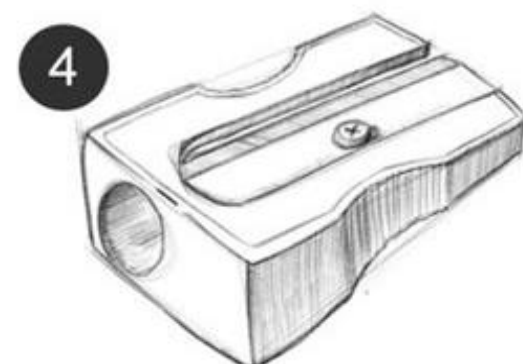
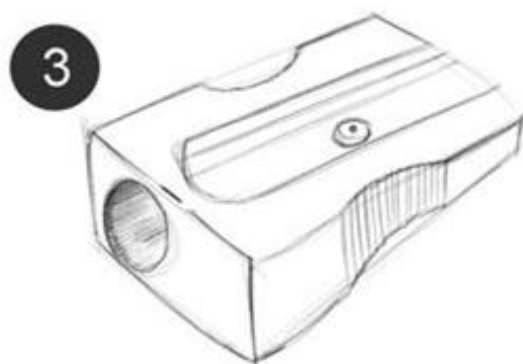

Draw your piece here...

To Do:

- Follow the 4 steps to draw one pencil sharpener.
- Measure the lengths of every line.
- Draw really lightly until you are happy with the shape.
- Do not 'make up' the drawing.

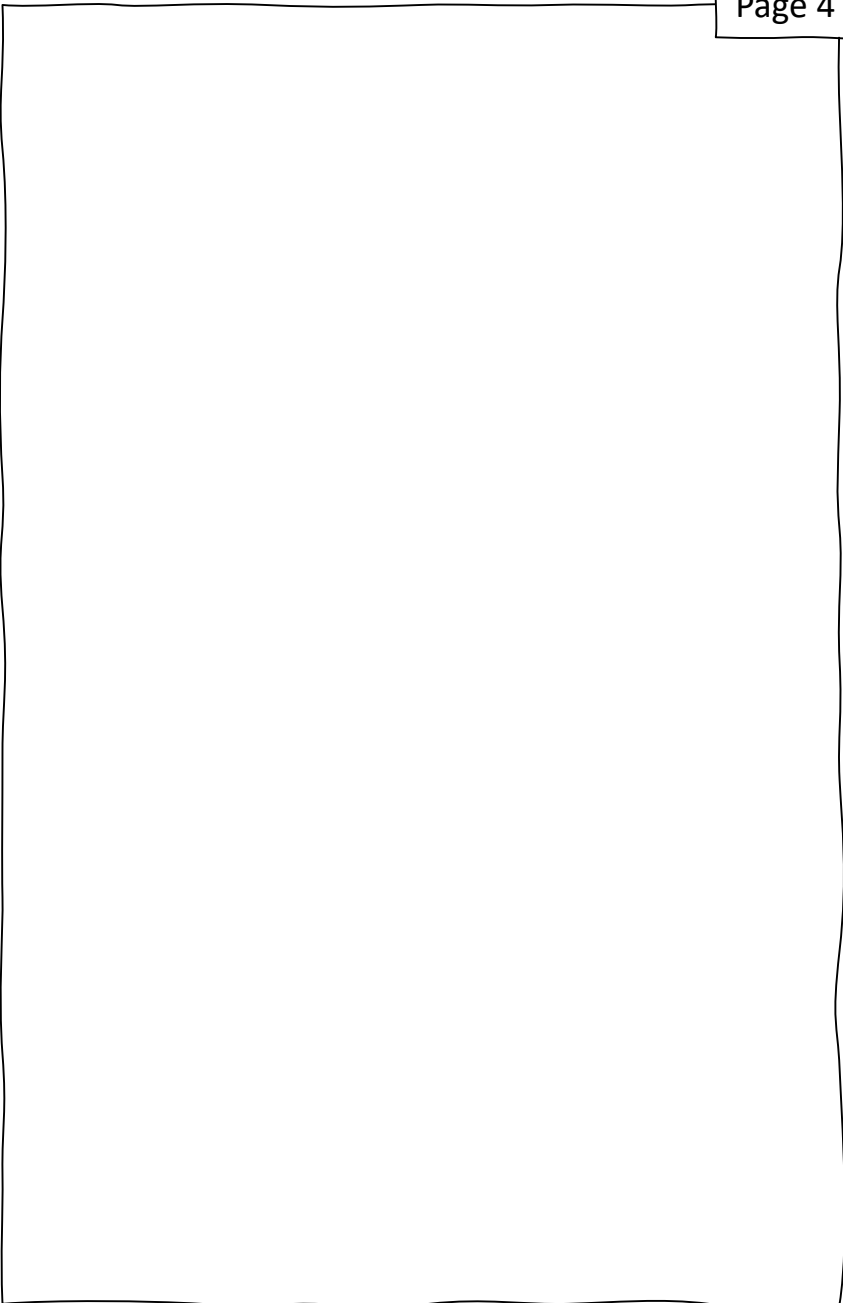

Copy the watch to scale here... ↑↑

Make sure to copy the shape,
proportions and mark making exactly.
The perspective is very important.

www.drawingforall.net/how-to-draw-a-watch

This website gives full step by step guidance
for drawing this watch.

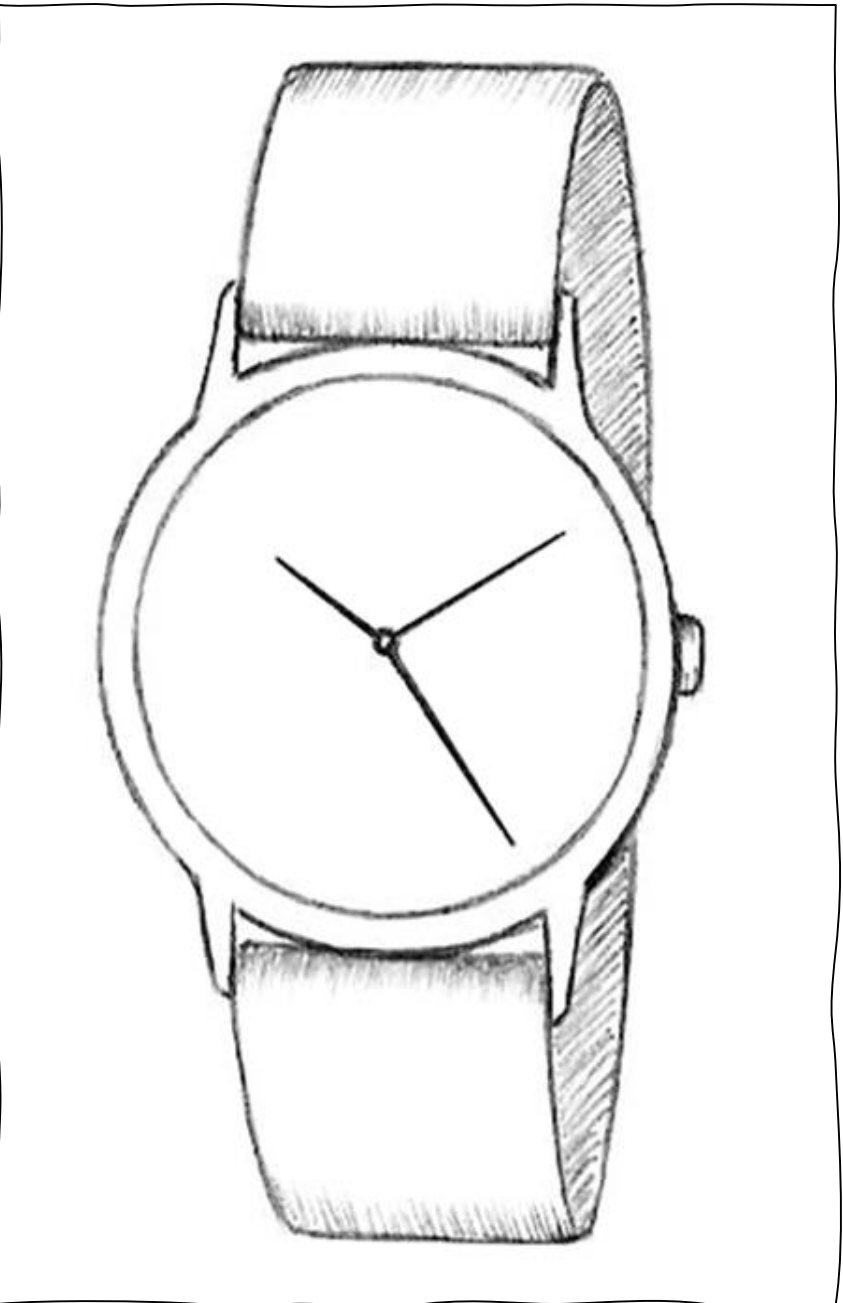

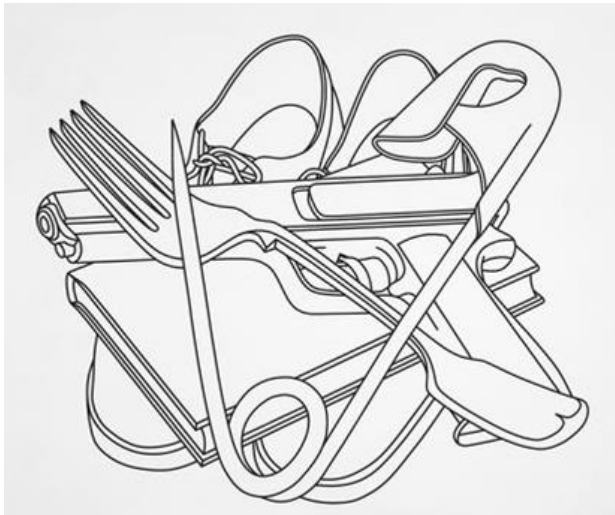

An Observational drawing is type of drawing. It's as simple and as complicated as that. It can be a flower, a person, a still life, a landscape, an object, whatever. But it's a drawing of something that have physically in front of you. Most Observational drawings also include tone to make them look 3D. Your drawing must not show tone.

To Do:

- Choose 4 basic everyday objects which you find interesting and would like to draw.
- Arrange the objects in an overlapping way.
- Create a line drawing of the objects, this means no shading!.

Remember: Look at the example above of Michael Craig Martins work.

Draw your piece here...

Michael Craig Martin also creates eye catching Typographic Posters. His lettering always has a distinct style. Its not bubble lettering or graffiti lettering. How would you describe his font?

I think his lettering is:

.....
.....
.....
.....

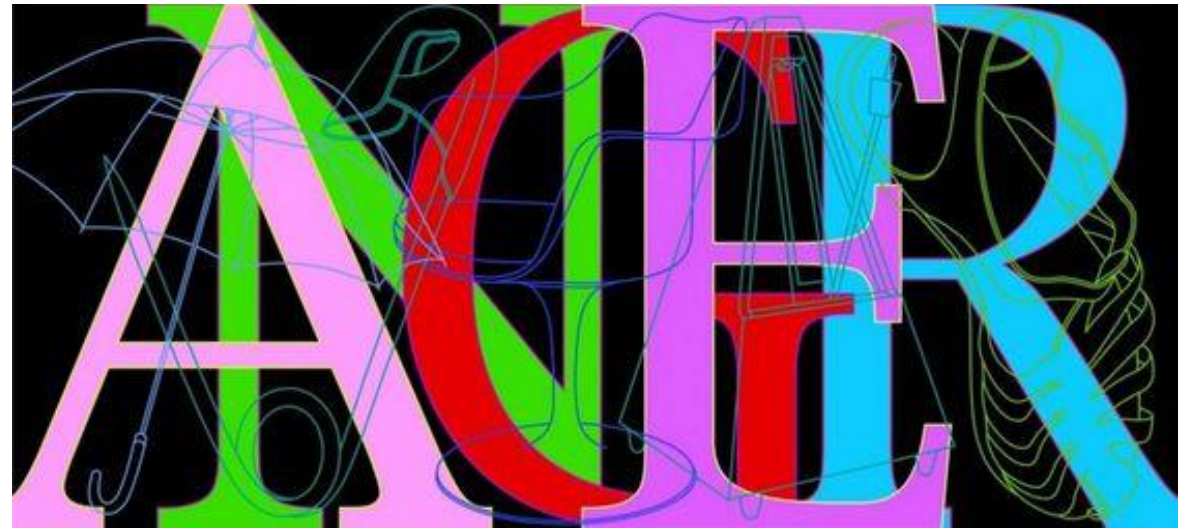
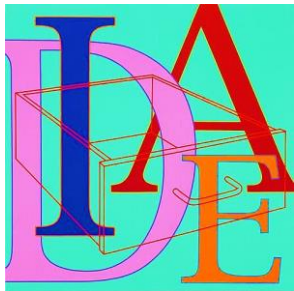

If you prefer to do this on the computer make sure you match on the font and colours. Then print out and place on this sheet.

Draw your copy here...

To Do:

- Accurately copy the shapes of the 'ANGER' artwork in the box provided. You do not have to draw the images behind the letters.
- Measure the lengths of every line.
- Draw really lightly until you are happy with the shape.
- Do not 'make up' the drawing.

Year 7 extended homework

You have 3 weeks to complete this part of the homework. **Choose 1 of the options:**

You only need to complete one option. Your homework must not be smaller than A5 or bigger than A4. Make sure you use suitable strong materials such as card, wire, glue. Your everyday objects must be well drawn, you can use any colour scheme, but you must outline all shapes with a thick black pen. This is your chance to show how creative you are as an artist. Enjoy the task and do your best! We look forward to seeing what you produce.

Option 2.
Create a Michael Craig Martin inspired **stacked sculpture** display of everyday objects that you can't live without.

Option 3.
Create a Michael Craig Martin inspired **sculpture pot** of everyday objects that you can't live without.

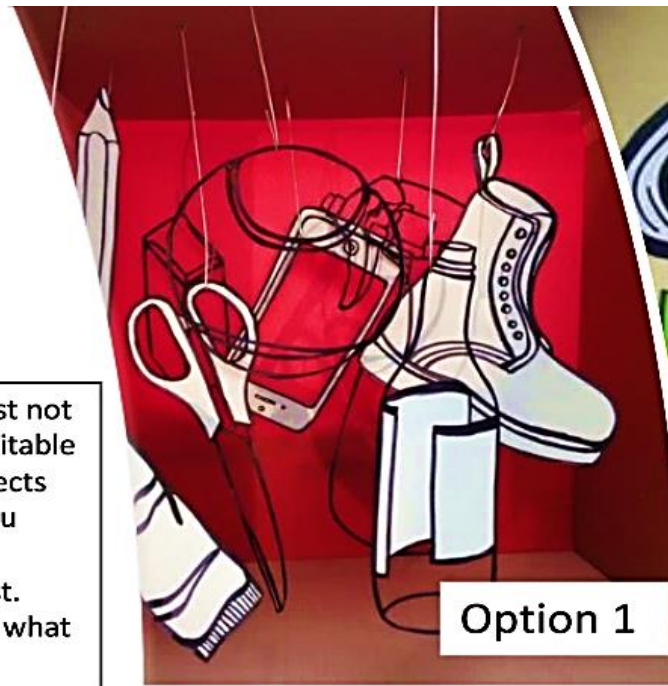

Option 1



Option 2



Option 3

These are photos to inspire your 4 week extended task.

They were made by previous year 7 pupils.



You can also look for inspiration on [pinterest.co.uk](https://www.pinterest.co.uk) and then search Michael Craig Martin.

Stick a photograph of your sculpture here

Extension Work 1: Colour in these compositions using the same bright bold colours as Michael Craig Martin.

