

Pythagoras' theorem

Student Book - Series 1-2

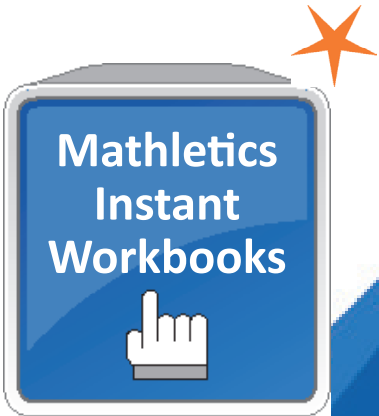
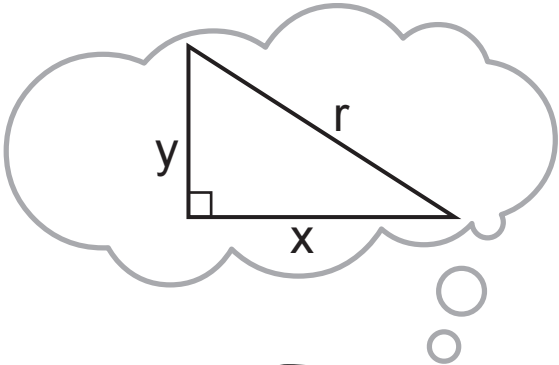

Pythagoras' theorem

Student Book - Series I 2

Contents

Topics	Date completed
Topic 1 - Naming the hypotenuse of a right-angled triangle	__/__/__
Topic 2 - Naming the sides of a right-angled triangle	__/__/__
Topic 3 - Selecting the correct Pythagoras' rule	__/__/__
Topic 4 - Squares and square roots	__/__/__
Topic 5 - Finding the length of the hypotenuse	__/__/__
Topic 6 - Finding the length of one of the other sides	__/__/__
Topic 7 - Mixed questions on Pythagoras' theorem	__/__/__
Topic 8 - Pythagorean triads	__/__/__
Topic 9 - Problem solving and Pythagoras' theorem	__/__/__

Practice Tests

Topic 1 - Topic test A	__/__/__
Topic 2 - Topic test B	__/__/__
Topic 3 - Topic test C	__/__/__

Author of The Topics and Topic Tests: AS Kalra

Pythagoras' theorem

Topic 1: Naming the hypotenuse of a right-angled triangle

QUESTION 1 Name the hypotenuse of each right-angled triangle.

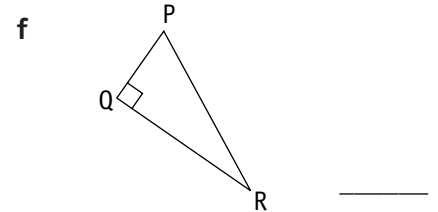
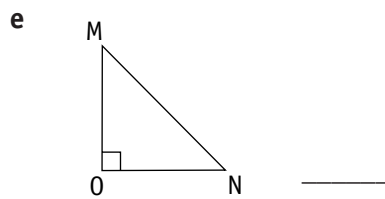
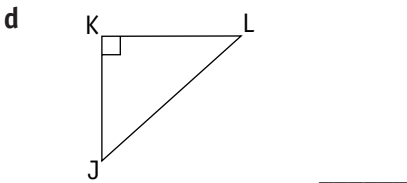
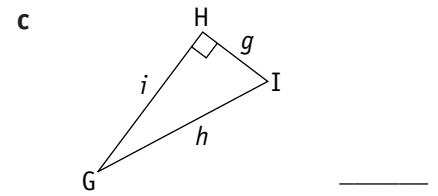
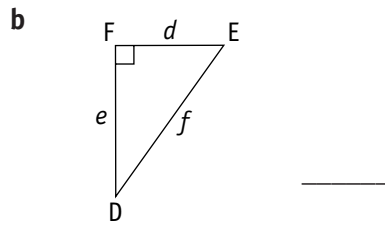
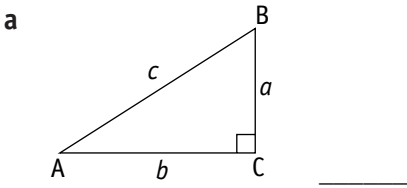

QUESTION 2 Name the hypotenuse of each named triangle.

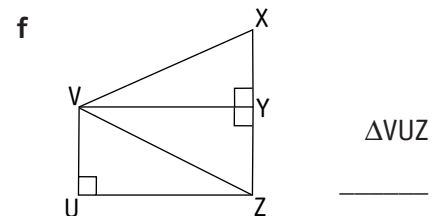
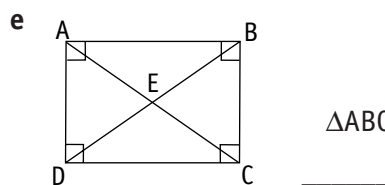
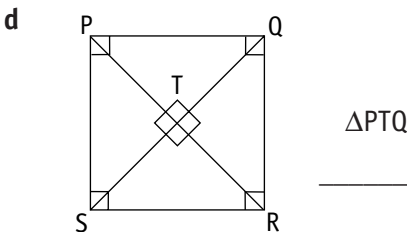
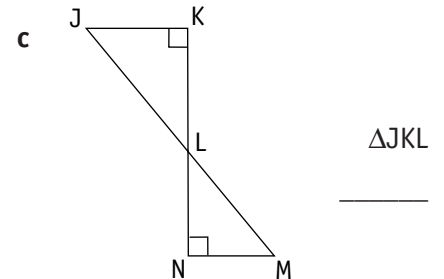
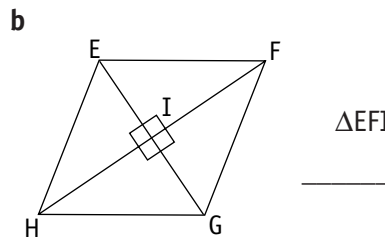
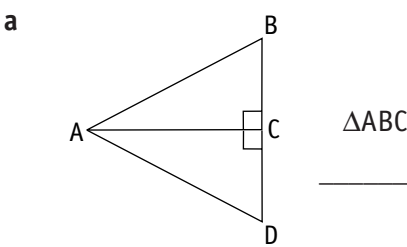

QUESTION 3 Complete the following statements.

- a _____ is the length of the hypotenuse.
- b _____ is the length of the side opposite $\angle A$
- c _____ is the length of the side opposite $\angle B$
- d _____ is the length of the side opposite $\angle C$
- e _____ is the area of the square on the side opposite $\angle A$
- f _____ is the area of the square on the side opposite $\angle B$
- g _____ is the area of the square on the side opposite $\angle C$
- h _____ is the name given to the longest side of $\triangle ABC$

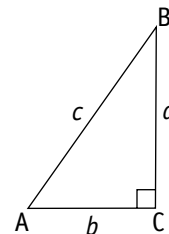

Pythagoras' theorem

Topic 2: Naming the sides of a right-angled triangle

QUESTION 1 Complete the table below for each of the following triangles and verify that the square on the hypotenuse is equal to the sum of the squares of the other two sides.

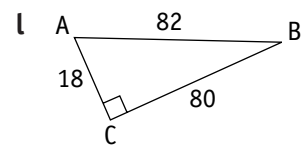
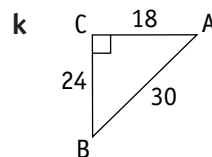
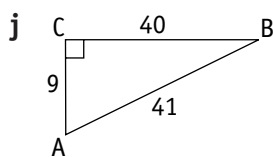
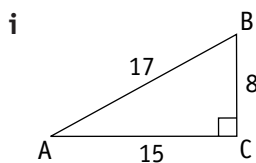
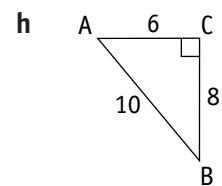
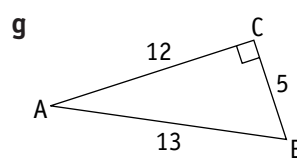
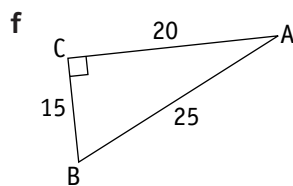
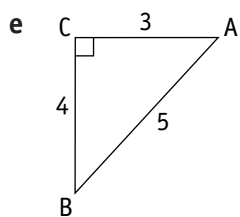
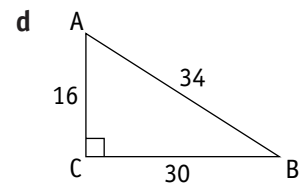
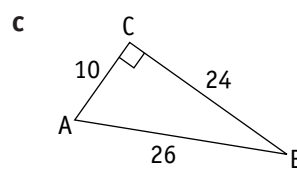
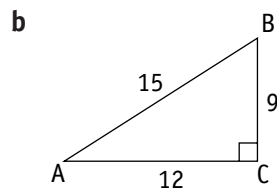
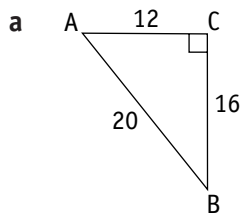

	a	b	c	a^2	b^2	c^2	$a^2 + b^2$
a							
b							
c							
d							
e							
f							
g							
h							
i							
j							
k							
l							

Pythagoras' theorem

Topic 3: Selecting the correct Pythagoras' rule

- 1** a $a^2 = b^2 + c^2$
 b $b^2 = a^2 + c^2$
 c $c^2 = a^2 + b^2$

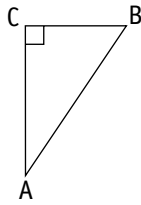

- 2** a $y^2 = a^2 + z^2$
 b $z^2 = a^2 + y^2$
 c $a^2 = y^2 + z^2$

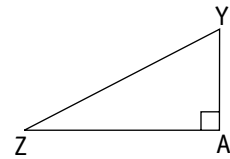

- 3** a $d^2 = e^2 + f^2$
 b $e^2 = d^2 + f^2$
 c $f^2 = d^2 + e^2$

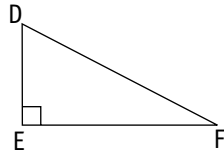

- 4** a $b^2 = c^2 + d^2$
 b $c^2 = b^2 + d^2$
 c $d^2 = b^2 + c^2$

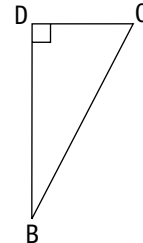

- 5** a $g^2 = h^2 + i^2$
 b $h^2 = g^2 + i^2$
 c $i^2 = g^2 + h^2$

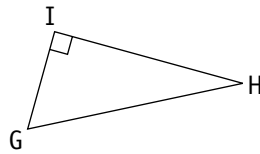

- 6** a $e^2 = f^2 + g^2$
 b $f^2 = e^2 + g^2$
 c $g^2 = e^2 + f^2$

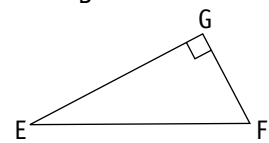

- 7** a $j^2 = k^2 + l^2$
 b $k^2 = j^2 + l^2$
 c $l^2 = j^2 + k^2$

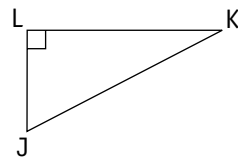

- 8** a $h^2 = i^2 + j^2$
 b $i^2 = h^2 + j^2$
 c $j^2 = h^2 + i^2$

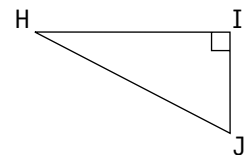

- 9** a $m^2 = n^2 + o^2$
 b $n^2 = m^2 + o^2$
 c $o^2 = m^2 + n^2$

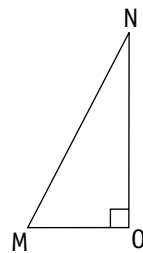

- 10** a $k^2 = l^2 + m^2$
 b $l^2 = k^2 + m^2$
 c $m^2 = k^2 + l^2$

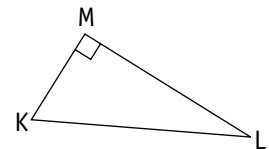

- 11** a $p^2 = q^2 + r^2$
 b $q^2 = p^2 + r^2$
 c $r^2 = p^2 + q^2$

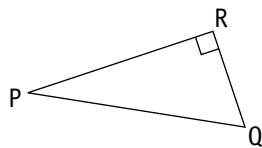

- 12** a $n^2 = o^2 + p^2$
 b $o^2 = n^2 + p^2$
 c $p^2 = n^2 + o^2$

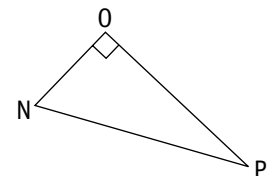

- 13** a $s^2 = t^2 + u^2$
 b $t^2 = s^2 + u^2$
 c $u^2 = s^2 + t^2$

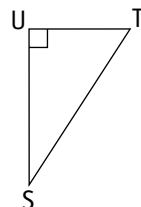

- 14** a $q^2 = r^2 + s^2$
 b $r^2 = q^2 + s^2$
 c $s^2 = q^2 + r^2$

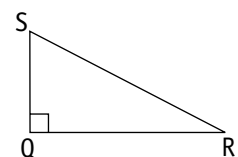

- 15** a $v^2 = w^2 + x^2$
 b $w^2 = v^2 + x^2$
 c $x^2 = v^2 + w^2$

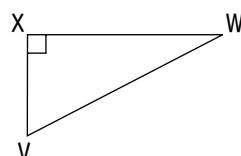

- 16** a $u^2 = v^2 + t^2$
 b $v^2 = u^2 + t^2$
 c $t^2 = u^2 + v^2$

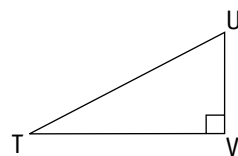

Pythagoras' theorem

Topic 4: Squares and square roots

QUESTION 1 Use your calculator to find the following squares.

- | | | |
|------------------|------------------|------------------|
| a $5^2 =$ _____ | b $15^2 =$ _____ | c $28^2 =$ _____ |
| d $31^2 =$ _____ | e $92^2 =$ _____ | f $9^2 =$ _____ |
| g $56^2 =$ _____ | h $7^2 =$ _____ | i $61^2 =$ _____ |
| j $32^2 =$ _____ | k $85^2 =$ _____ | l $78^2 =$ _____ |

QUESTION 2 Use the square root key to find the following.

- | | | |
|------------------------|-----------------------|------------------------|
| a $\sqrt{4} =$ _____ | b $\sqrt{1} =$ _____ | c $\sqrt{9} =$ _____ |
| d $\sqrt{16} =$ _____ | e $\sqrt{49} =$ _____ | f $\sqrt{64} =$ _____ |
| g $\sqrt{25} =$ _____ | h $\sqrt{81} =$ _____ | i $\sqrt{100} =$ _____ |
| j $\sqrt{144} =$ _____ | k $\sqrt{36} =$ _____ | l $\sqrt{121} =$ _____ |

QUESTION 3 Use your calculator to find x .

- | | | |
|--------------------------|---------------------------|---------------------------|
| a $x = \sqrt{784}$ _____ | b $x = \sqrt{289}$ _____ | c $x = \sqrt{1369}$ _____ |
| d $x = \sqrt{169}$ _____ | e $x = \sqrt{196}$ _____ | f $x = \sqrt{2401}$ _____ |
| g $x = \sqrt{441}$ _____ | h $x = \sqrt{1156}$ _____ | i $x = \sqrt{324}$ _____ |
| j $x = \sqrt{256}$ _____ | k $x = \sqrt{225}$ _____ | l $x = \sqrt{3969}$ _____ |

QUESTION 4 Square the following.

- | | | |
|---------------------|----------------------|-----------------------|
| a $(1.3)^2 =$ _____ | b $(5.6)^2 =$ _____ | c $(7.9)^2 =$ _____ |
| d $(5.2)^2 =$ _____ | e $(6.7)^2 =$ _____ | f $(8.35)^2 =$ _____ |
| g $(8.3)^2 =$ _____ | h $(8.32)^2 =$ _____ | i $(11.25)^2 =$ _____ |
| j $(9.7)^2 =$ _____ | k $(5.41)^2 =$ _____ | l $(22.2)^2 =$ _____ |

QUESTION 5 Use the square key to find the following squares.

- | | | |
|----------------------|---------------------|----------------------|
| a $(5.61)^2 =$ _____ | b $(3.2)^2 =$ _____ | c $(6.31)^2 =$ _____ |
| d $(7.8)^2 =$ _____ | e $(5.3)^2 =$ _____ | f $(13.5)^2 =$ _____ |
| g $(5.9)^2 =$ _____ | h $(6.8)^2 =$ _____ | i $(15.2)^2 =$ _____ |
| j $(6.7)^2 =$ _____ | k $(9.2)^2 =$ _____ | l $(8.95)^2 =$ _____ |

QUESTION 6 Find the square roots correct to 1 decimal place.

- | | | |
|-------------------------|--------------------------|-------------------------|
| a $\sqrt{5.4} =$ _____ | b $\sqrt{6.58} =$ _____ | c $\sqrt{52.7} =$ _____ |
| d $\sqrt{8.1} =$ _____ | e $\sqrt{3.25} =$ _____ | f $\sqrt{93.8} =$ _____ |
| g $\sqrt{7.69} =$ _____ | h $\sqrt{6.75} =$ _____ | i $\sqrt{62.1} =$ _____ |
| j $\sqrt{8.23} =$ _____ | k $\sqrt{8.123} =$ _____ | l $\sqrt{73.8} =$ _____ |

Pythagoras' theorem

Topic 5: Finding the length of the hypotenuse

QUESTION 1 Find the length of the hypotenuse in each of the following triangles.
All measurements are in centimetres.

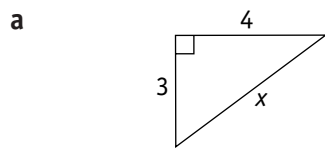

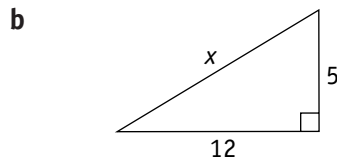

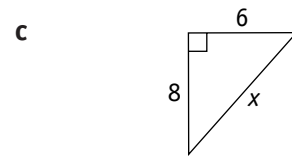

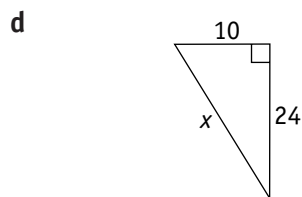

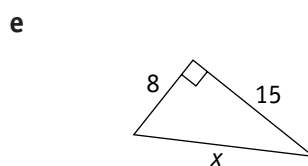

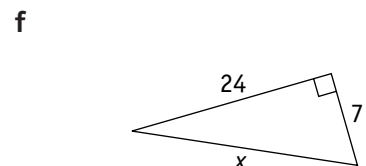

QUESTION 2 Find the length of the hypotenuse correct to 1 decimal place.
All measurements are in centimetres.

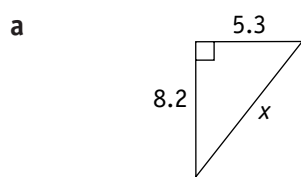

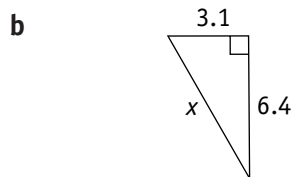

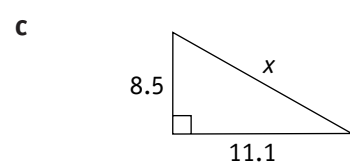

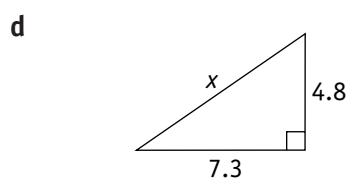

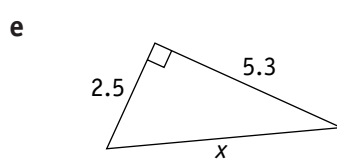

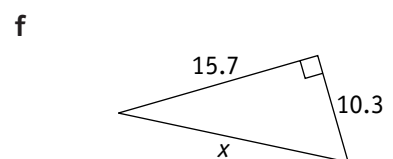

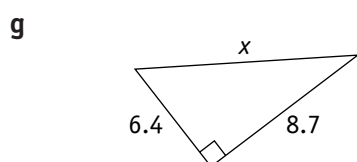

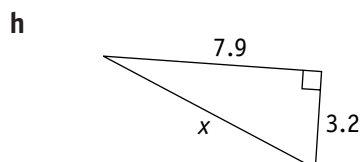

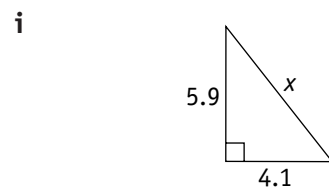

Pythagoras' theorem

Topic 6: Finding the length of one of the other sides

QUESTION 1 Find the length of the unknown side in each of the following triangles.
All measurements are in centimetres.

a

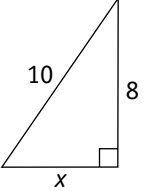

b

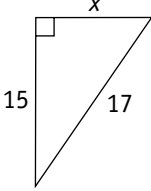

c

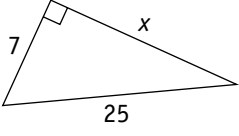

d

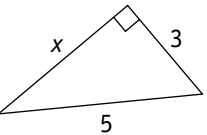

e

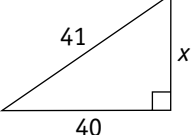

f

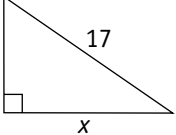

QUESTION 2 Find the length of the unknown side correct to 2 decimal places.
All measurements are in centimetres.

a

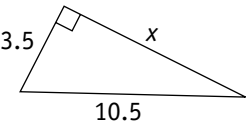

b

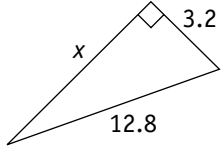

c

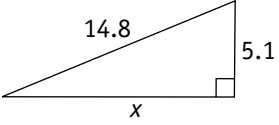

d

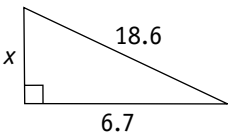

e

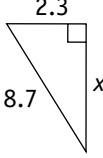

f

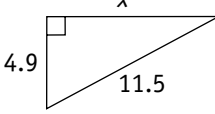

g

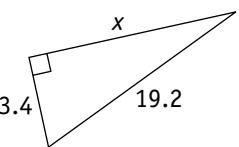

h

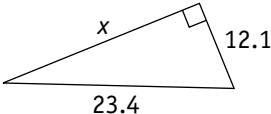

i

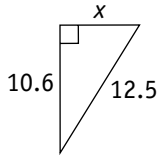

Pythagoras' theorem

Topic 7: Mixed questions on Pythagoras' theorem

QUESTION 1 In each of the following triangles find the length of the unknown side.
All measurements are in centimetres.

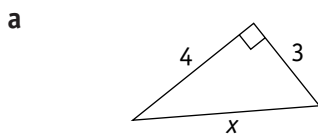

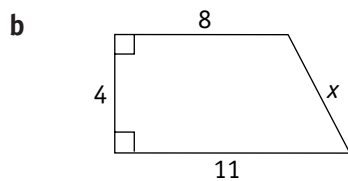

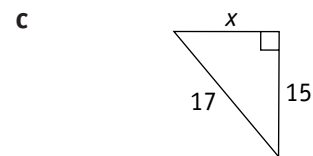

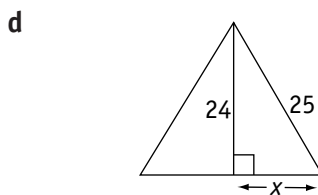

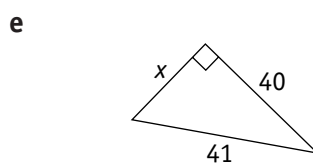

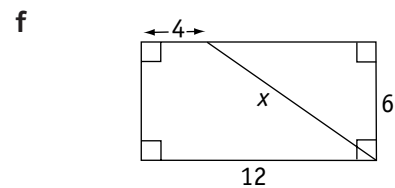

QUESTION 2 Find the length of the unknown side correct to one decimal place.
All measurements are in centimetres.

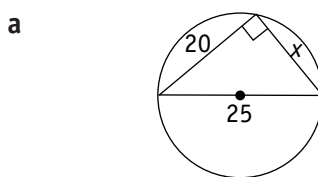

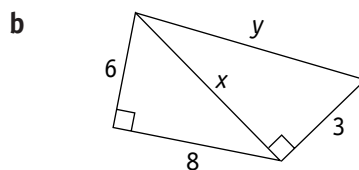

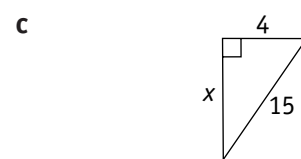

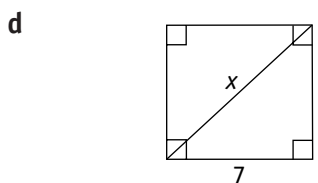

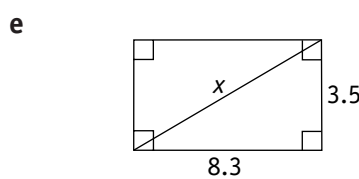

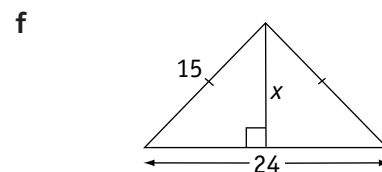

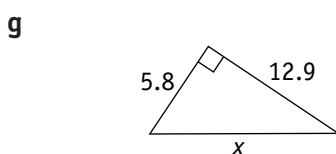

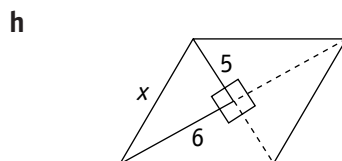

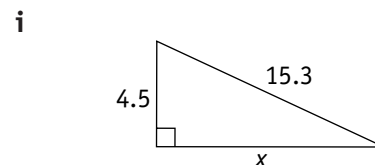

Pythagoras' theorem

Topic 8: Pythagorean triads

QUESTION 1 Which of the following are Pythagorean triads?

- | | | | | | | | | |
|---|-------------|-------|---|-------------|-------|---|--------------|-------|
| a | {2, 4, 5} | _____ | b | {7, 12, 13} | _____ | c | {4, 12, 13} | _____ |
| d | {8, 10, 12} | _____ | e | {3, 4, 5} | _____ | f | {6, 8, 10} | _____ |
| g | {5, 12, 13} | _____ | h | {8, 13, 17} | _____ | i | {8, 15, 17} | _____ |
| j | {7, 24, 25} | _____ | k | {9, 40, 41} | _____ | l | {16, 30, 34} | _____ |

QUESTION 2 Prove that the following triangles are right-angled triangles.

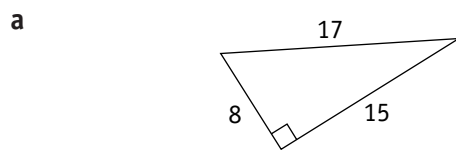

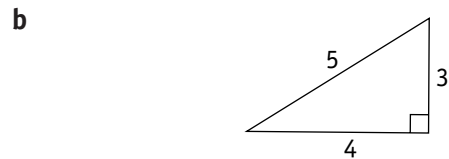

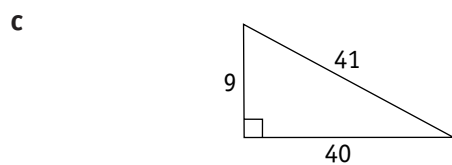

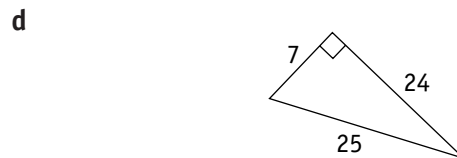

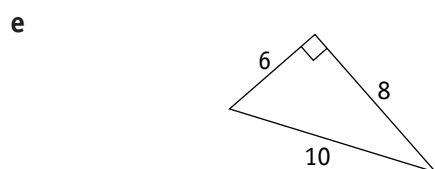

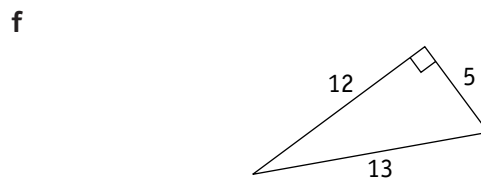

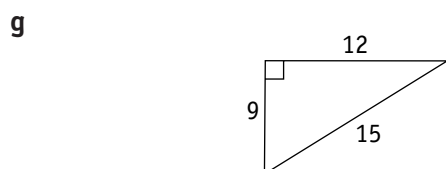

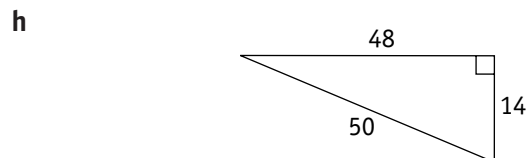

Pythagoras' theorem

Topic 9: Problem solving and Pythagoras' theorem

Find the length of the unknown side correct to 1 decimal place. All measurements are in centimetres.

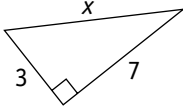
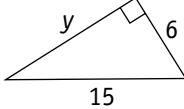
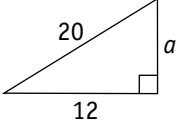
1  **2**  **3** 

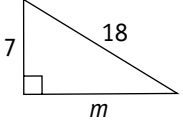
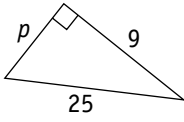
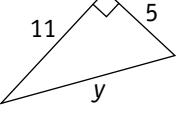
4  **5**  **6** 

7 Find the length of the diagonal of a rectangle of length 28 cm and width 9 cm. (Answer correct to 1 decimal place.)

8 Find the length of the diagonal of a square of side length 7 cm. (Answer correct to 1 decimal place.)

9 What is the altitude of an equilateral triangle whose sides are each 12 cm? (Answer correct to 2 decimal places.)

10 In a right-angled triangle, the longest side is 49 cm and the shortest side is 12 cm. Find the length of the third side correct to 2 decimal places.

11 The hypotenuse of a right-angled triangle is 45 cm. If one of the short sides is 16 cm, find the length of the other side to 2 decimal places.

12 A 6 metre ladder rests against a wall and its foot is 3 metres away from the base of the wall. How high does the ladder reach up the wall? (Answer correct to 2 decimal places.)

Find the length of the unknown side in each of the following triangles. (Answers correct to 2 decimal places.)

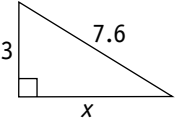
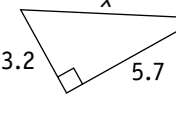
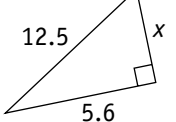
13  **14**  **15** 

Pythagoras' theorem

Topic Test

PART A

Instructions This part consists of 12 multiple-choice questions
Each question is worth 1 mark
Fill in only ONE CIRCLE for each question
Calculators are NOT allowed

Time allowed: 15 minutes

Total marks = 12

	Marks
1 $\sqrt{5}$ is closest to <input type="radio"/> (A) 2 <input type="radio"/> (B) 2.2 <input type="radio"/> (C) 2.23 <input type="radio"/> (D) 2.24	<input type="text" value="1"/>
2 Which of the following is not a Pythagorean triad? <input type="radio"/> (A) {6, 8, 10} <input type="radio"/> (B) {5, 12, 13} <input type="radio"/> (C) {9, 40, 41} <input type="radio"/> (D) {7, 25, 26}	<input type="text" value="1"/>
3 The Pythagorean result for a triangle ABC with hypotenuse BC is <input type="radio"/> (A) $a^2 = b^2 + c^2$ <input type="radio"/> (B) $b^2 = a^2 + c^2$ <input type="radio"/> (C) $a^2 = c^2 - b^2$ <input type="radio"/> (D) $c^2 = b^2 + a^2$	<input type="text" value="1"/>
4 If two sides of a right-angled triangle are 7 cm and 24 cm, then the hypotenuse is <input type="radio"/> (A) 23 cm <input type="radio"/> (B) 24 cm <input type="radio"/> (C) 25 cm <input type="radio"/> (D) 31 cm	<input type="text" value="1"/>
5 In a right-angled triangle, the side opposite the right angle is called the <input type="radio"/> (A) shortest side <input type="radio"/> (B) middle side <input type="radio"/> (C) hypotenuse <input type="radio"/> (D) none of these	<input type="text" value="1"/>
6 Which one of the following triads determines a right-angled triangle? <input type="radio"/> (A) {8, 9, 12} <input type="radio"/> (B) {11, 10, 15} <input type="radio"/> (C) {9, 11, 20} <input type="radio"/> (D) {16, 30, 34}	<input type="text" value="1"/>
7 Pythagoras' theorem can be applied to <input type="radio"/> (A) acute-angled triangles <input type="radio"/> (B) obtuse-angled triangles <input type="radio"/> (C) right-angled triangles <input type="radio"/> (D) any triangle	<input type="text" value="1"/>
8 Find the area of a rectangle which has a diagonal 10 cm long and one side 6 cm long. <input type="radio"/> (A) 40 cm ² <input type="radio"/> (B) 48 cm ² <input type="radio"/> (C) 60 cm ² <input type="radio"/> (D) 80 cm ²	<input type="text" value="1"/>
9 Given that $c^2 = a^2 + b^2$ and $a = 10$ and $b = 24$, what is the value of c ? <input type="radio"/> (A) 26 <input type="radio"/> (B) 28 <input type="radio"/> (C) 576 <input type="radio"/> (D) 676	<input type="text" value="1"/>
10 The hypotenuse of a right-angled triangle is 17 cm. If one side is 8 cm, the third side is <input type="radio"/> (A) 9 cm <input type="radio"/> (B) 11 cm <input type="radio"/> (C) 13 cm <input type="radio"/> (D) 15 cm	<input type="text" value="1"/>

Pythagoras' theorem

Topic Test

PART A continued

	Marks
11 Which of the following is a Pythagorean triad? (A) {5, 10, 17} (B) {5, 12, 13} (C) {5, 12, 14} (D) {5, 20, 25}	1
12 A triangle is said to satisfy the rule $c^2 = a^2 + b^2$ for which special triangle? (A) acute-angled (B) right-angled (C) obtuse-angled (D) any	1
13 The longest side of a right-angled triangle is called the (A) shortest side (B) middle side (C) hypotensue (D) none of these	1
14 If $n^2 = 625$ then n equals (A) 15 (B) 25 (C) 35 (D) 45	1
15 The two shorter sides of a right-angled triangle have lengths 12 cm and 5 cm. What is the square of the length of the hypotenuse? (A) 13 (B) 119 (C) 169 (D) 289	1
Total marks achieved for PART A	15

Pythagoras' theorem

Topic Test

PART B

Instructions This part consists of 15 questions
 Each question is worth 1 mark
 Write answers in the answers-only column

Time allowed: 20 minutes

Total marks = 15

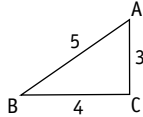
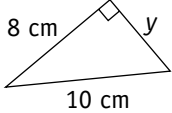
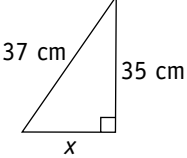
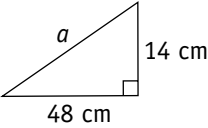
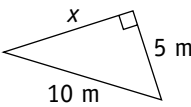
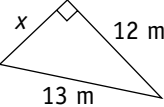
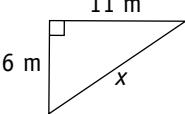
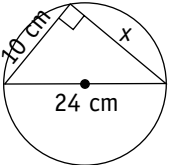
Questions	Answers only	Marks
1 If $a^2 = 4761$, find the value of a	_____	1
2 Is $\{8, 15, 17\}$ a Pythagorean triad?	_____	1
3 Is $\triangle ABC$ a right-angled triangle?	_____	1
		
Find the value of the unknown side in each triangle below.		
4 	_____	1
5 	_____	1
6 	_____	1
Find the length of the unknown side in each triangle correct to 2 decimal places.		
7 	_____	1
8 	_____	1
9 	_____	1
10 If the two shorter sides of a right-angled triangle are 9 cm and 11 cm, find the hypotenuse.	_____	1
11 Find the length of the diagonal of a square of side 8 cm.	_____	1
12 Find the height of an equilateral triangle whose sides are 16 cm.	_____	1
13 Find the length of the diagonal of a rectangle of length 20 cm and width 8 cm.	_____	1
14 Find the value of x .	_____	1
		
15 The hypotenuse of a right-angled triangle is 42 cm. If one of the short sides is 20 cm, find the length of the other side.	_____	1

Total marks achieved for PART B

15

Pythagoras' theorem

Topic Test

PART C

Instructions This part consists of 4 questions
 Each question is worth 5 marks
 Show all necessary

Time allowed: 20 minutes

Total marks = 20

Questions

Marks

- 1** a Find c given that $c^2 = 12^2 + 5^2$ _____ b Find a given that $100 = a^2 + 64$ _____
 c Find $\sqrt{225}$ _____ d Find x  _____
 e The longest side in a right-angled triangle is called the _____.

5

- 2** a A triangle is said to satisfy the rule $c^2 = a^2 + b^2$ for which special triangle?

- b Find c  _____

- c The longest side of a right-angled triangle is 17 cm. If one side is 15 cm, find the length of the third side. _____

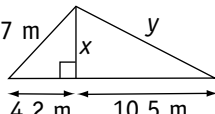
- d Find x in the given triangle.  _____
 e Find y in the given triangle. _____

5

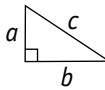
- 3** a State Pythagoras' theorem in terms of a , b and c .  _____

- b  $x =$ _____ c  $x =$ _____

- d Find x in the given diagram. _____

- e Find y in the given diagram.  _____

5

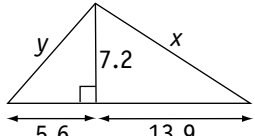
- 4** a  $x =$ _____
 $y =$ _____

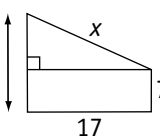
- b  $x =$ _____

- c A ladder 3.8 m long is leaning against a wall. The foot of the ladder is 1.4 m away from the bottom of the wall. How far up the wall does the ladder reach?

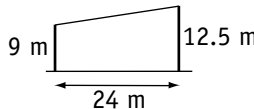
- d Two flag posts are 9 m and 12.5 m long and 24 m apart. Find the length of the string needed to join the tops of the two posts.  _____

5

Total marks achieved for PART C

20